

DEPARTMENT OF THE ARMY TECHNICAL MANUAL

OPERATOR, ORGANIZATIONAL

DIRECT SUPPORT AND GENERAL SUPPORT

MAINTENANCE MANUAL

INCLUDING

REPAIR PARTS AND SPECIAL TOOL LISTS

PUMP, RECIPROCATING, DIAPHRAGM
100 GPM, LESS MIL STD ENGINE
(REX CHAINBELT MODEL 4DG)
FSN 4320-063-7363

This copy is a reprint which includes current pages from Changes 6 and 7.

HEADQUARTERS, DEPARTMENT OF THE ARMY
DECEMBER 1968

SAFETY PRECAUTIONS

BEFORE OPERATION

When filling the fuel tank, do not smoke or use open flame in the immediate vicinity. Always provide a metal-to-metal contact between the container and the fuel tank. This will prevent a spark from being generated as fuel flows over metallic surfaces. Failure to observe this warning may result in death to personnel.

Make sure spark plug leads are disconnected before performing maintenance on the pump.

Avoid breathing smoke when using a monobromotrifluoromethane fire extinguisher.

DURING OPERATION

Never operate the reciprocating pump in an enclosed area unless the exhaust gases are piped to the outside. Exhaust gases contain carbon monoxide which is a colorless, odorless; and poisonous gas.

Do not fill the fuel tank while the engine is in operation. Gasoline spilled on a hot engine may explode and cause serious injury to personnel.

Do not attempt to perform any maintenance on the pump while the engine is running. Never operate the pump without a strainer on the suction line.

AFTER OPERATION

When lifting the pumping unit, be sure the lifting device has a lifting capacity of at least 750 lbs. Do not allow the pumping unit to swing while suspended. Failure to observe this warning may result in damage to the unit or severe injury to personnel.

Avoid breathing smoke when using a monobromotrifluoromethane fire extinguisher.

CHANGE
NO. 7

HEADQUARTERS,
DEPARTMENT OF THE ARMY
WASHINGTON, D. C., 10 April 1991

Operator, Organizational
Direct Support and General Support
Maintenance Manual Including Repair Parts and Special Tools Lists
PUMP, RECIPROCATING, DIAPHRAGM
100GPM, LESS MIL STD ENGINE
(REX CHAINBELT MODEL 4DG)
NSN 4320-00-063-7363

Approved for public release; distribution is unlimited

TM 5-4320-252-14, 11 December 1968, is changed as follows:

Page A-4, Section II, Basic Issue Items List. Add information after Group 31, 3100 Basic Issue Items Manufacturer or Depot Installed, Rope. Insert in: column (1) (A): P, column (1) (B): c, column (2): 5120-00-277-9077, column (3): Wrench, Spanner, Adjustable, 3-6 in DIA Coupling, 12 IN LG., column (4): EA, column (7): 2, and column (8): 2.

By Order of the Secretary of the Army:

CARL E. VUONO
General, United States Army
Chief of Staff

Official:

THOMAS F. SIKORA
Brigadier General, United States Army
The Adjutant General

DISTRIBUTION:

To be distributed in accordance with DA Form 12-25E, (qty rqr block no. 1417)

Change in force: C6

Change }
No.6 }

HEADQUARTERS
DEPARTMENT OF THE ARMY
WASHINGTON, D.C., 30 November 1987

**Operator, Organizational, Direct Support
and General Support Maintenance Manual
Including Repair Parts and Special Tool Lists
PUMP, RECIPROCATING, DIAPHRAGM,
100 GPM, LESS MIL STD ENGINE
(REX CHAINBELT MODEL 4DG)
NSN 4320-00-063-7363**

TM 5-4320-252-14, 11 December 1968, is changed as follows:

All changes, additions, or deletions of National stock numbers or manufacturer's part numbers should be appropriately reflected in the parts listing and index of the manual.

Page i. Immediately after title add the following:

REPORTING ERRORS AND RECOMMENDING IMPROVEMENTS

You can help improve this manual. If you find any mistake or if you know of a way to improve the procedures, please let us know. Mail your letter, DA Form 2028 (Recommended Changes to Publications and Blank Forms), or DA Form 2028-2 located in the back of this manual direct to: Commander, U.S. Army Troop Support Command, ATTN: AMSTR-MCTS, 4300 Goodfellow Boulevard, St. Louis, MO 63120-1798.

A reply will be furnished directly to you.

In the table of contents the appendixes are superseded as follows:

APPENDIX A.	REFERENCES	A-1
APPENDIX B.	COMPONENTS OF END ITEM LIST	B-1
APPENDIX C.	MAINTENANCE ALLOCATION CHART	C-1
APPENDIX D.	REPAIR PARTS AND SPECIAL TOOLS LIST	D-1
APPENDIX E.	EXPENDABLE SUPPLIES AND MATERIALS LIST	E-1

1.1 Scope

This manual contains instructions for the use of operator, organizational, direct support and general support personnel maintaining the pump as allocated by the Maintenance Allocation Chart. It provides information on the operation, preventive maintenance services, lubrication, and maintenance of the equipment, its accessories and components.

1.2 Forms and Records

DA Forms and records used for equipment maintenance will be only those prescribed by DA PAM 738-750.

Page ii. Illustrations C-1 through C-4 are reidentified as D-1 through D-4. Page numbers C-28, C-29, C-30, and C-32 are reidentified as U-2Z, D-29, D-30 and D-32.

Page 2. Paragraphs 1.1 and 1.2 are added after paragraph 1.

Page 4. Paragraph 10B. In line 3, change "TM 5-2805-257-14" to read "LO 5-2805-257-12".

*This change supersedes C4, 29 December 1978 and C5, 20 October 1986.

Page 7. Figure 9. In line 1, change “consult Engine Manual (TM 5-2805-257-14)” to read “See Lubrication Order LO 5-2805-257-12”.

Page 10. After paragraph 22K add the following note:

NOTE

Movement of bearing (BB) in gearcase housing is a normal characteristic of this pump.

Paragraph 23A is superseded as follows:

A. The oil slinger and setscrew (EE) are not required for proper gearcase lubrication. Remove the oil slinger and setscrew when maintenance is performed on the gearcase.

Page C-16, Figure C3, item 36, change SMR code “PFR” to read “PAFHH”. Change Federal Stock Number “2805-072-4871” to read “2805-01-169-1100”. Add reference No. and MFR code “(97403) 2A016-4”.

Page 11. Figure 6. Delete EE and reference there to from illustration.

Page A-1. Appendix A is superseded as follows:

APPENDIX A

REFERENCES

A-1. Fire Protection

TM 5-4200-200-10

Hand Portable Fire Extinguishers for Army Users

A-2. Lubrication

C9100IL
LO 5-2805-257-12

Fuel, Lubrication, Oil and Waxes
Lubrication Order

A-3. Painting

TM 913

Painting Instructions for Field Use

A-4. Maintenance

TM 5-2805-257-14

Operator, Organizational, Direct and General Support for
MILITARY STANDARD ENGINES

DA Pam 738-750

The Army Maintenance Management System (TAMMS)

A-5. Shipment and Storage

TM 740-90-1

Administrative Storage

A-6. Destruction to Prevent Enemy Use

TM 750-244-3

Procedures for Destruction to Prevent Enemy Use

Page B-1. Appendix B is superseded as follows:

APPENDIX B

COMPONENTS OF END ITEM LIST

Section I. INTRODUCTION

B-1. Scope

This appendix lists integral components of and basic items for the Diaphragm Pump to help you inventory items required for safe and efficient operation.

B-2. General

This components of End Item List is divided into the following sections:

a. Section II. Integral Components of the End Item. These items, when assembled, comprise the Diaphragm Pump and must accompany it whenever it is transferred or turned in. The illustrations will help you identify these items.

b. Section III. Basic Issue Items. These are the minimum essential items required to place the Diaphragm Pump in operation, to operate it, and to perform emergency repairs. Although shipped separately packed, they must accompany the Diaphragm Pump during operation and whenever it is transferred between accountable officers. The illustrations will assist you with hard-to-identify items. This manual is your authority to requisition replacement BII, based on TOE/MTOE authorization of the end item.

B-3. Explanation of Columns

a. Illustration. This column is divided as follows:
 (1) Figure Number. Indicates the figure number of the illustration on which the item is shown.
 (2) Item Number. The number used to identify item called out in the illustration.

b. National Stock Number. Indicates the National stock number assigned to the item which will be used for requisitioning.

c. Part Number. Indicates the primary number used by the manufacturer, which controls the design and characteristics of the item by means of its engineering drawings, specifications, standards, and inspection requirements to identify an item or range of items.

d. Description. Indicates the Federal item name, and, if required, a minimum description to identify the item.

e. Location. The physical location of each item listed is given in this column. The lists are designed to inventory all items in one area of the major item before moving on to an adjacent area.

f. Usable on Code. "USABLE ON" codes are included to help you identify which component items are used on the different models. Identification of the codes used in these lists are:

Code	Used On
BCU	

g. Quantity Required (Qty Reqd). This column lists the quantity of each item required for a complete major item.

h. Quantity. This column is left blank for use during an inventory. Under the Rcv'd column, list the quantity you actually receive of your major item. The Date columns are for your use when you inventory the major item at a later date, such as for shipment to another site.

Section II. INTEGRAL COMPONENTS OF END ITEM

(1) Illustration		(2) National Stock Number	(3) Part No.	(4) Description	(5) Location	(6) Usable On Code	(7) Qty Reqd	(8) Quantity			
(a) Figure No.	(b) Item No.							Rcv'd	Date	Date	Date
D-2	1	4730-00-256-7130		NIPPLE, PIPE		BCU	2				
D-2	2	4720-00-202-8653	ZZH561 Type 1 (81349)	HOSE		BCU	4				

Section II. INTEGRAL COMPONENTS OF END ITEM

(1) Illustration		(2) National Stock Number	(3) Part No.	(4) Description	(5) Location	(6) Usable On Code	(7) Qty Reqd	(8) Quantity			
(a) Figure No.	(b) Item No.							Rcv'd	Date	Date	Date
				L05-4320-252-12		BCU	1				
				M5-4320-252-14		BCU	1				
				L05-2805-257-12		BCU	1				
				TM5-2805-257-14		BCU	1				
		5120-00-449-8083		WRENCH. OPEN END ADJUSTABLE		BCU	1				
		2990-00-972-7	9509786E 121 (97403)	ROPE STARTING		BCU	1				

Page C-1. Appendix C is changed as follows:

Pages B-1 through B-6 are reidentified as pages C-1 through C-6.

Paragraphs B-1 through B-3 are reidentified as paragraphs C-1 through C-3.

Page D-1. Appendix D is changed as follows:

Pages C-1 through C-34 are reidentified as pages D-1 through D-34.

Paragraphs C-1 through C-8 are reidentified as paragraphs D-1 through D-8.

In Sections III and IV, Column 8a, all references to figure numbers will be changed from C to D.

Make the following changes in Sections II and III.

Section II. PRESCRIBED LOAD ALLOWANCE

Page	Line	Action	(1) National stock number	(2) Description	(3) Qty Inc in unit pack	(4) 15-day org maint, alw			
						(a) 1-5	(b) 6-20	(c) 21-50	(d) 51-100
D-8	3	Ch colm 1; ch manufacturer code in P/N in colm 2.	5315-00-241-2920 (54275) X7298	5501-RODS, BEARINGS, DIAPHRAGM PIN, DOWEL: Rod mtg					2

Section III. Repair parts for organizational maintenance

Page	Line	Action	(1) SMR code index no.	(2) National stock number	(3) Description Reference No & mfr code	(4) Unit of issue	(5) Qty Inc in unit pack	(6) Qty Inc in unit	(7) 15 day organizational maint allowance				(8) Illustrations	
									(a) 1-5	(b) 6-20	(c) 21-50	(d) 51-100	(a) Figure No.	(b) Item or symbol no.
D-12 i	89	Ch colm 2; add manufacturer code and P/N n colm 3.	PO	5315-00-241-2920	Group 55-PUMPS 5500-PUMPS ASSEMBLY PIN, DOWEL: Rod mtg (54275) X7298.									

Make the following changes in Section IV.

Section IV. REPAIR PARTS FOR DS AND GS MAINTENANCE

Page	Line	Action	(1) SMR code index No.	(2) National stock number unit	(3) Description Reference o. & Usable mfg code on code	(4) Unit of issue	(5) Qty inc in unit pack	(6) Qty inc in	(7) 30-day DS maint allowance			(8) 30-day GS maint allowance			(9) 1-yr alw per 100 equip cntgy No.	(10) Depot maint alw per 100 equip No.	(11) Illus- tration	
									(a) 1- 20	(b) 21- 50	(c) 51- 100	(a) 1- 20	(b) 21- 50	(c) 51- 100			(a) Fig.	(b) Item
D-21	89	Ch colm 2; Add mfr code and P N in colm 3.	PO	5315-00-241-2920	Group 55 - PUMPS 5502 - RODS, BEARINGS, DIAPHRAGM PIN. DOWEL Rod mtg (54275) X7298													
D-24	132	Add nmfr code and P/N in colm 3.	PF	4320-00-724-1357	5507 - PUMP DRIVE REDUCTION GEARCASE GEAR, SPUR: Speed reducing (53786) 81994A.													
D-25	142	Add col 2.	PF	5340-00-112-1342	RING, RETAINING: Spur gear (53786) X7229.													

Page E-1. Appendix E is added as follows:

APPENDIX E

EXPENDABLE SUPPLIES AND MATERIALS LIST

Section I. INTRODUCTION

E-1. Scope

This appendix lists expendable supplies and materials you will need to operate and maintain the Diaphragm Pump. These items are authorized to you by CTA 50-970, Expendable Items (Except Medical, Class V, Repair Parts, and Heraldic Items).

E-2. Explanation of Columns

a. Column 1 - Item number. This number is assigned to the entry in the listing and is referenced in the narrative instructions to identify the material (e.g., "Using cleaning solvent, item 1, App. E").

b. Column 2 - Level. This column identifies the lowest level of maintenance that requires the listed item.

C - Operator/Crew

c. Column 3 - National Stock Number. This is the National stock number assigned to the item; use it to request or requisition the item.

d. Column 4 - Description. Indicates the Federal item name and, if required, a description to identify the item. The last line for each item indicates the part number followed by the Federal Supply Code for Manufacturer (FSCM) in parentheses, if applicable.

e. Column 5 - Unit of Measure (U/M). Indicates the measure used in performing the actual maintenance function. This measure is expressed by a two-character alphabetical abbreviation (e.g., ea, in, pr). If the unit of measure differs from the unit of issue, requisition the lowest unit of issue that will satisfy your requirements.

Section II. EXPENDABLE SUPPLIES AND MATERIALS LIST

(1) ITEM NUMBER	(2) LEVEL	(3) NATIONAL STOCK NUMBER	(4) DESCRIPTION	(5) U/M
1	C	6850-00-281-1985	Solvent, Cleaning	gl
2	C	9150-00-402-4478	Oil, Engine, Subzero	qt
3	C	9150-00-186-6681	Oil, Engine, OE-30	qt
4	C	9130-00-160-1818	Gasoline, Combat	bulk
5	C	9150-00-190-0904	Grease, Automotive and Artillery (GAA)	lb

By Order of the Secretary of the Army:

OFFICIAL:

R. L. DILWORTH
Brigadier General, United States-Army
The Adjutant General

CARL E. VUONO
General, United States Army
Chief of Staff

DISTRIBUTION:

To be distributed in accordance with DA Form 12-25A, Operator, Unit, Direct Support and General Support Maintenance requirements for Pump, Reciprocating, Diaphragm, 100 GPM, Less Engine (4DG).

OPERATOR, ORGANIZATIONAL, DIRECT SUPPORT
AND GENERAL SUPPORT MAINTENANCE MANUAL
INCLUDING REPAIR PARTS AND SPECIAL TOOLS LIST

PUMP, RECIPROCATING, DIAPHRAGM,
100 GPM, LESS MIL STD ENGINE
(REX CHAINBELT MODEL 4DG)
FSN 4320-063-7363
CURRENT AS OF 1 October 1968

	Page
CHAPTER I. GENERAL	
Description	2
Application.....	2
Data Plates.....	2
II. PREPARATION BEFORE USE	3
III. OPERATING INSTRUCTIONS	4, 5
IV. MAINTENANCE	
Daily	6
Semi-Yearly.....	6
Service Check List.....	6
Lubrication.....	7
Pump Repair	8 thru 12
APPENDIX A. BASIC ISSUE ITEMS LIST	A-1
B. MAINTENANCE ALLOCATION CHART	B-1
C. REPAIR PARTS AND SPECIAL TOOLS LIST	C-1
Section I. Introduction.....	C-1
II. Prescribed Load Allowance	C-8
III. Repair Parts for Organizational Maintenance	C-9
IV. Repair Parts for DS and GS Maintenance	C-16
V. Federal Stock Number and Reference Number Index	C-32

LIST OF ILLUSTRATIONS

Number	Title	Page
1	Reciprocating pump	1
1A	Transportation data plate.....	2
1B	Pump data plate.....	2
1C	Engine data plate	2
2	Pump inlet hose	3
2A	Reciprocating pump service points and engine controls	4
3	End view - pump body.....	5
3A	Pump body and valves.....	9
4	Pump body and adjacent parts	8
5	Connecting rod.....	9
6	Gear reduction cases	11
7	Discharge side of pump.....	12
8	Wheel hub assembly.....	12
9	Lubrication chart	7
C-1	Diaphragm and connecting rod.....	C-28
C-2	Pump body and valves.....	C-29
C-3	Reduction gearcase	C-30
C-4	Pump frame	C-32

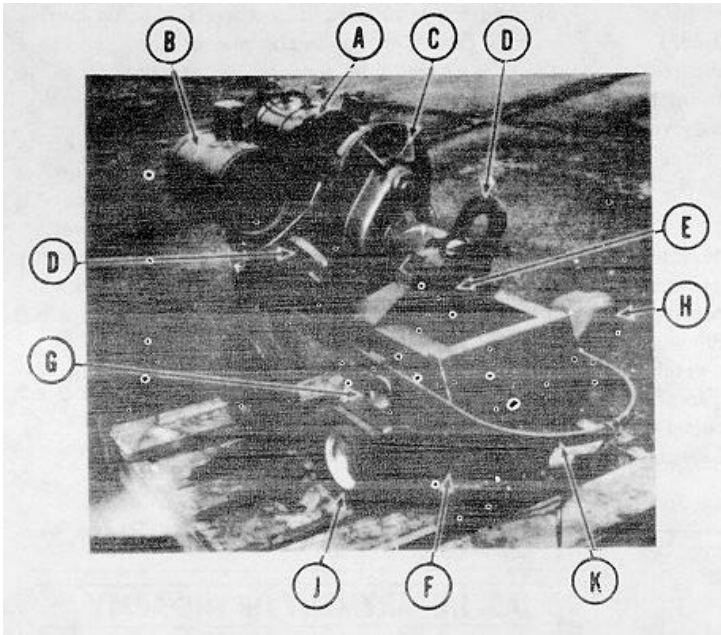

- A. Engine
- B. Engine Fuel Tank
- C. Pump Reduction Case
- D. Lifting Device
- E. Pump Connecting Rod
- F. Pump Body
- G. Priming Cap
- H. Outlet Side
- J. Inlet Side
- K. Towing Bail

FIGURE 1 RECIPROCATING PUMP.

CHAPTER I - GENERAL

1. Description - The REX Model MBG Diaphragm Pump is a positive displacement type pump powered by a military standard Model 2A016 (FSN2805-0724871) air cooled engine. The pump and engine are mounted on a common frame and is trailer mounted. 4" inlet and outlet valves are bolted to the pump body to which the suction and discharge lines are fitted. (Engine maintenance and parts are covered in TM 5-2805- 257-14).

The main operating part of the pump is its flexible rubber diaphragm. The outer edge of the diaphragm is secured to the rim of the pump body. A connecting rod fastened to the diaphragm center moves it up and down. As it is lifted, it creates a vacuum which draws liquid into the pump body. As the diaphragm is forced down, it forms a pressure which simultaneously closes the inlet valve and opens the out-let valve.

2. Application - The Model MBG Diaphragm Pumps are utilized for dewatering jobs where the liquid carries a high percentage of trash, mud or sand, or where there is a variable seepage of water, such as in trench work.

Where slow water seepage and high suction lift is encountered, the use of a foot valve at the end of the suction line is recommended. This addition will facilitate priming and help maintain a dry excavator. (A foot valve is a flap type valve which opens with the suction stroke of the pump and closes with the discharge stroke, thus the suction line is always full of water after the suction line is filled.)

CAUTION: A strainer must be used on suction hose to prevent entrance of stones into the pump.

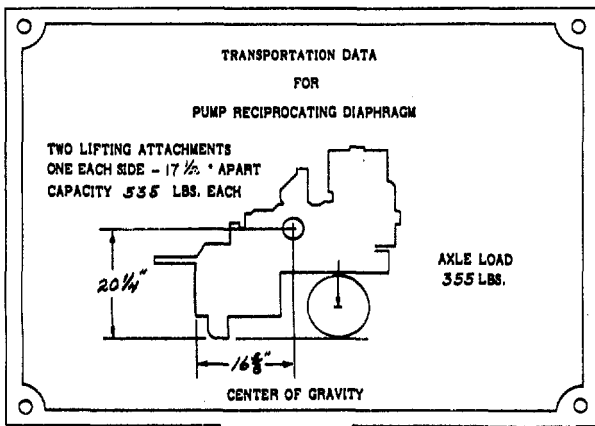

Figure 1A
TRANSPORTATION DATA PLATE

3. Pump Data Plate - Engine Data Plate-Trans. Data Plate.

U.S. DEPARTMENT OF THE ARMY			
PUMP, RECIPROCATING, DIAPHRAGM			
MODEL	4D-G	CAPACITY	
SER		YEAR OF MANUFACTURE	1967
ENG SER NO.			INSP STAMP
REGISTRATION NO.			
FSN	2320-063-7363	CONT NO.	DAAK01-C-A534
SHIPPING WT.	570	LB. GROSS VEHICLE WT.	425 LB.
OVERALL HEIGHT	32 1/4	IN. WIDTH	31 1/2
		IN LENGTH	46 1/2
WARRANTY	6	MO OR	MI DATE SHIP
MFD. BY	REX CHAINBELT INC.		

Figure 1B
PUMP DATA PLATE



Figure 1C ENGINE DATA PLATE

CHAPTER II - PREPARATION BEFORE USE

4. Unpacking and inspection - The pump is boxed and secured within the box. Upon unpacking, make a visual inspection for any damage or theft in transit. Manuals are contained in a canvas bag for each pump. If pump is to be lifted, see the transportation data plate (Fig. 1A) for lifting. Lifting "eyes" are provided on each side of the pump frame. Four 10' long sections of 4" diameter hose with two 4" diameter close nipples are contained in one box for each pump.
5. Assembly - The rubber diaphragm has been removed from the pump at the factory and must be reinstalled on the pump before operation. Remove preservative before installation. For installation of the rubber diaphragm, refer to Chapter IV, Paragraph 18. Thread the 4" close nipples into the inlet and outlet valves. Nipples (A) must be tight with no air leaks. (Reference Fig. 4)

The towing bail may be extended or repositioned for easier hand towing.

Suction and discharge hose are connected to the pump at the jobsite.

6. Lubrication before use - The engine crankcase, pump gearcase and connecting rod bearing grease cup are filled to level points at the factory. However, before operation these points should be checked for oil levels. Refer to lubrication chart, Page 7, Fig. 9 for data.

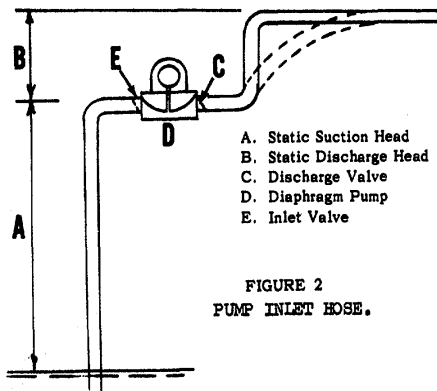

FIGURE 2
PUMP INLET HOSE.

FIGURE 2

7. Selection and preparation of pump site - The pump inlet should not be located higher than 25 feet above the source of liquid to be pumped. (Fig. 2) The pump is capable of pumping against a total dynamic head of 35' which is a combination of (A) and (B) in Fig. 2, but the Static Suction Head is not to exceed 25' (measured vertically) above the inlet valve from water level. This would leave a 10' Static Discharge Head (measured vertically). These figures are based on using a suction line of same nominal inside diameter as pump inlet (4"), and one elbow and are calculated at sea level atmospheric conditions. For maximum pumping efficiency it is recommended that the discharge line be elevated above the height of the discharge valve. This retains a back pressure against the discharge valve on the suction stroke of the diaphragm. Pump should be setting level and as close to the liquid to be pumped as possible. Adequate working space should be provided around the pump for Inspection and servicing.

CAUTION: Care should be exercised that the wire reinforced hose is not crimped or flattened as this will increase priming time and decrease pumping capacity.
8. Hose Installation - The suction and discharge hoses are equipped with Type B1 Rocker Lug Type Couplings and thread onto the inlet valve and outlet valve pipe nipples. The connections are to be threaded tight especially on the suction side of the pump to prevent air leaks. Air leaks will increase priming time and reduce pump capacity.
 - A. Suction Hose - The hose connected to the inlet or suction side of the pump should be of the rigid type (non-collapsible). Hose should be free of any breaks, cuts, pin holes or have a collapsed liner. When the pumping application permits, the suction line should be kept as short as possible.
 - B. Discharge Hose - Hose on the outlet or discharge side of the pump may be of the collapsible type, but the rigid type is preferable. On long discharge lines, the line should be one size, and sometimes two sizes larger than the discharge fitting of the pump, in order to decrease frictional loss.
9. Movement to new worksite - Disconnect the suction and discharge hose from the pump. Drain pump body by removing the pump drain plug, reference, Fig. 7. If extremely hi-solid content water, mud or mucky water has been pumped, the pump body should be flushed out with clean water. The clean-out door may be removed for this purpose, reference, Fig. 3 and 7.

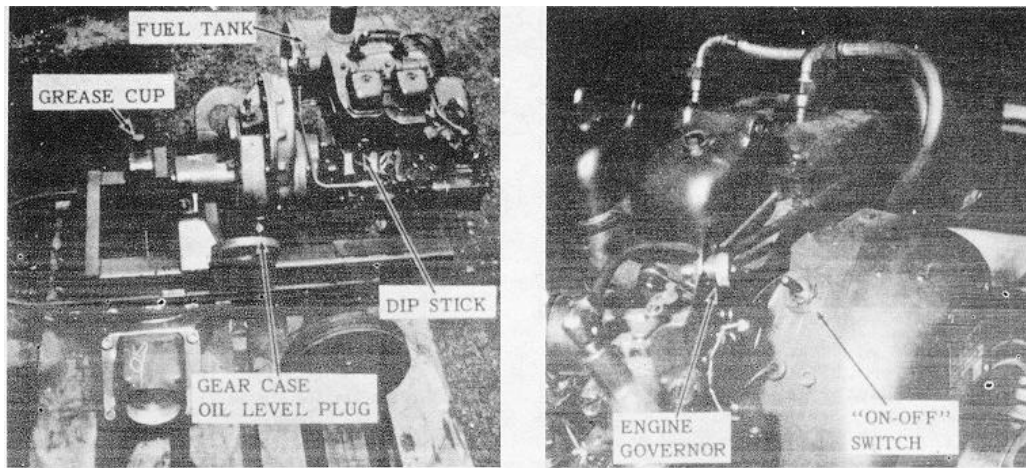

FIGURE 2A RECIPROCATING PUMP SERVICE POINTS AND ENGINE CONTROLS.

CHAPTER III - OPERATING INSTRUCTIONS

10. Starting - Fig. 2A.

- A. Fill engine fuel tank (1.5 gallons). Regular motor fuel "Mogas".
- B. Check engine crankcase oil level. Remove dip stick. Observe level indicated. Add oil if necessary. See Lubrication order TM 5-2805-257-14.
- C. Check oil level in pump reduction gearcase. Re-move oil level plug. Oil should be to this level. Add oil if necessary.
- D. Hand turn down grease cup cap slightly on top of the connecting rod needle bearing to force grease to the bearing.
- E. Connect suction hose to pump and place in liquid to be pumped.
- F. Connect discharge hose and place accordingly.
- G. Remove pump body priming cap and fill pump body with liquid.
- H. Replace priming cap tight on pump body.
- I. Flip engine "on-off" switch to the "on" position.
- J. Close choke valve.
- K. Start engine with engine starter rope
- L. Open choke valve slowly to obtain smooth engine operation.

11. Stopping - Fig. 2A - Shut off engine by flipping the "on-off" switch to "off" position. If pump is to remain in its present location, engine need only be shut off.

12. Normal operation - The operation of the pump is dependent on the volume or supply of liquid to be pump-ed. When shallow suction lifts with little liquid to be pumped is encountered, reduce engine speed. To govern the engine speed, loosen the spring loaded knurled knob. Actuate knob forward or back in slotted hole to gain the desired engine speed. This will reduce the load on the engine resulting in reduced fuel consumption. On high suction lifts, it will be necessary to keep the engine speed higher.

Although the diaphragm pump is self-priming, the initial prime can be speeded up as outlined under par. 10. Filling the pump body with liquid helps to seal off the inlet and outlet valves from taking in air.

13. Cold weather operation - Cold or freezing weather should not effect the operation of the pump as long as water is being drawn into and passed thru the pump body. However, at the close of pumping operations, the pump body should be thoroughly drained by removing the pump body and discharge valve drain plugs reference, Fig. 7. Leave drain plugs out if pump is to be left outside. Replace plugs before starting operation. If hi-solid content water has been pumped, remove the clean-out door, reference, Fig. 7 and flush out pump body with clear water.

14. Pump body clean-out door - Fig. 3 - A clean-out door is provided for quick inspection and clean-out. After pumping off muddy, sludge water, or water containing chemical harmful to rubber, the pump body should be flushed out with clean water. Access to the inside of the pump body is made by removing four wing nuts holding clean-out door to pump body and remove door, replace door and rubber gasket. Turn wing nuts down tightly.

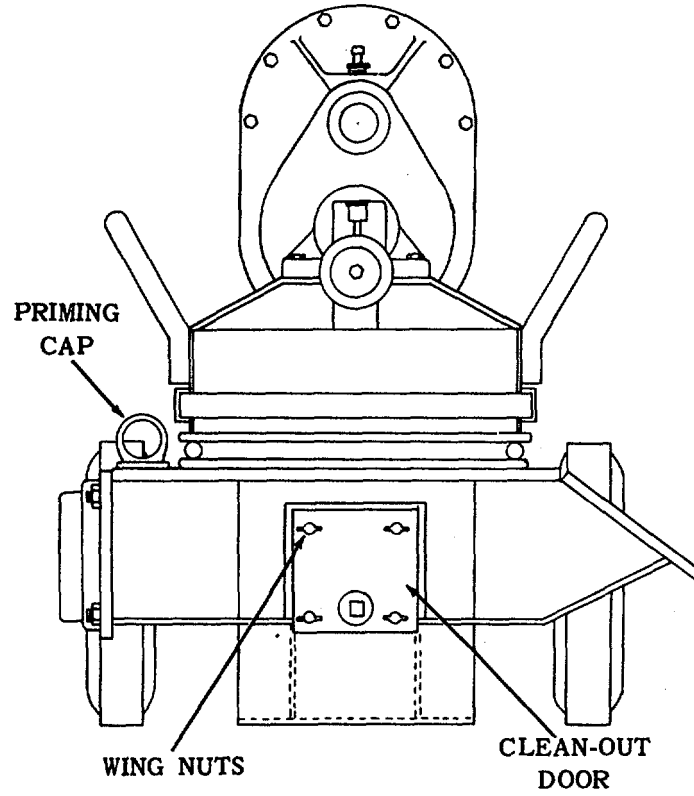

FIGURE 3
END VIEW - PUMP BODY

CHAPTER IV - MAINTENANCE

15. Daily maintenance, reference Fig. 9.
- A. Check engine crankcase oil level every 5 hours and change every 25 hours. Dip stick on side of engine. Add oil if necessary.
 - C. Check pump gearcase oil level. Remove oil level plug on side of gearcase. Add oil if necessary.
 - D. Check connecting rod bearing grease cup. To lubricate bearing, hand turn down grease cup cap one quarter turn, twice daily. Fill cup as required.
 - E. Flush out pump body with clean water.
 - F. During freezing weather, make sure pump body is drained after pumping. Remove suction line from liquid.

16. Semi-Yearly, reference Fig. 9.
- A. Engine - Consult "Engine Manual "(TM 5-2805-257-14).
 - B. Pump gearcase - Drain, flush and refill gearcase to level plug. Capacity 2 pints.
 - C. Connecting rod bearing grease cup. Remove cup from connecting rod. Clean, flush and refill cup.
 - D. Inspect rubber diaphragm. Should the rubber show signs of cracking, replace the diaphragm. Refer to diaphragm replacement par. 18.
 - E. Inspect the inlet and outlet rubber flap valves. Should the rubber flap valves show signs of wear or cracking, replace flap valves. Refer to pars. 19 and 20.
 - F. Inspect the connecting rod needle bearing. Refer to connecting rod needle bearing replacement par. 21. If inspection indicates bearing is worn, it should be replaced.
 - G. Wheel bearings - The wheels contain two sealed type ball bearings with no provision for lubrication. Bearings are presealed at the factory.

17. Service Check List

- A. Priming
 - 1. Initial prime - failure to prime initially may be due to:
 - a. Suction lift too high. Total lift must be no greater than 25 feet.
 - b. Suction leak - Check hose connections, check valve and seat gasket, diaphragm for cracks and make sure that inlet end of suction is submerged in liquid but not buried in mud and/or foreign matter.
 - c. Valve leak - Check for proper seating and easy operation.

- 2. Loss-of-prime - Loss of prime after initial prime has been established may be due to the same conditions as outlined above for initial prime.

B. Low Capacity

- 1. Failure to deliver rated capacity may be due to any of the following causes:
 - a. Suction lift too high. Reposition pump as required.
 - b. Discharge point too high. Change discharge system as required.
 - c. Suction leaks - Check as indicated under priming.
 - d. Collapsed suction line. Make sure suction hose lining is not loose, or line crimped.
 - e. Clogged suction - Clean suction inlet.
 - f. Reduced engine speed - Make sure engine is properly serviced and adjusted. (Connecting rod should operate at approximately 60 strokes per minute.)

C. Valve Noise

Both the suction and check valves should close with a distinct slap. A change to a very loud snap indicates excessively high suction and/or discharge. Make sure that the installation does not exceed the maximums. (Reference, Chapter II, Par. 7 and Fig. 2.)

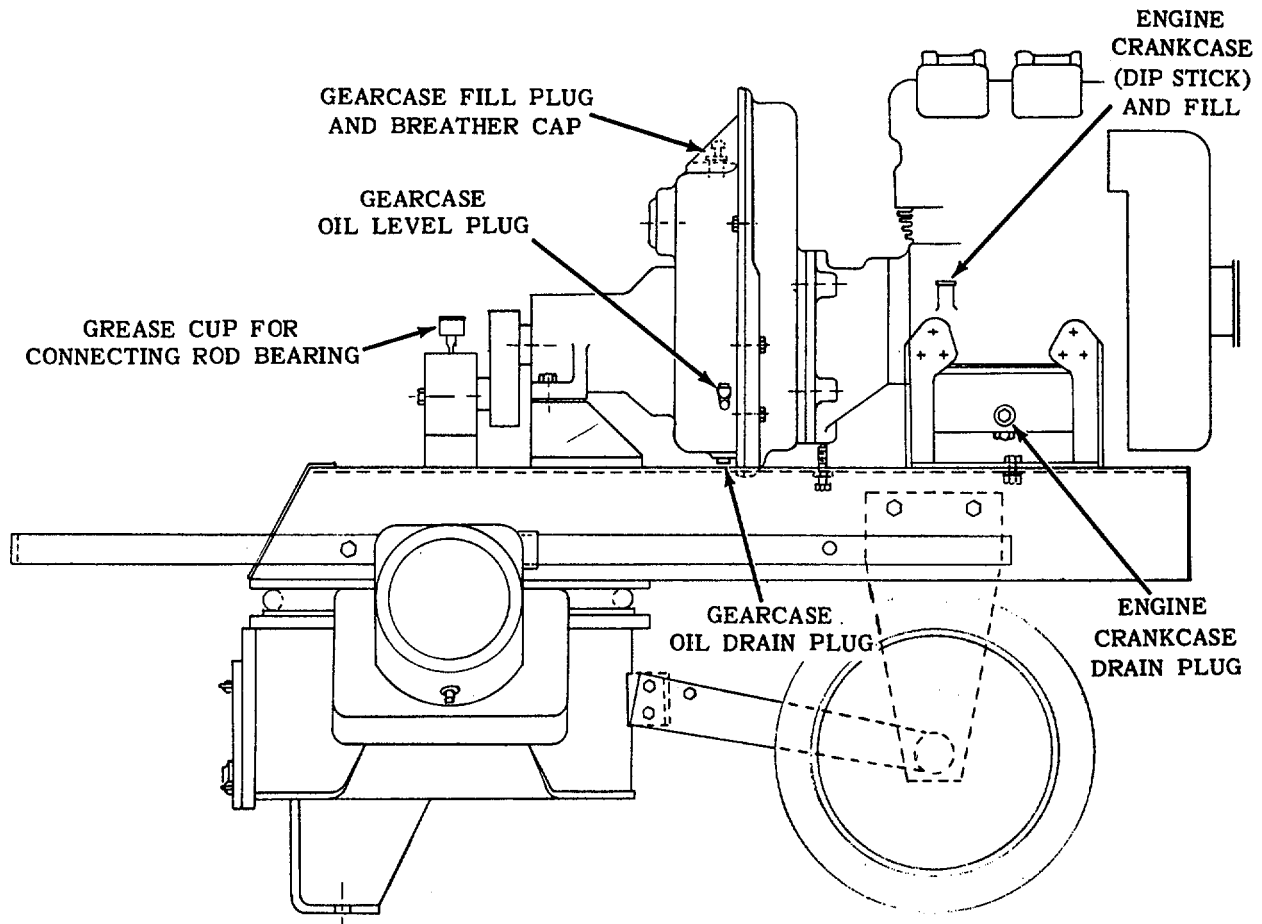

FIGURE 9
LUBRICATION CHART

Engine Crankcase - Consult "Engine Manual "(TM 5-2805-257-14),
Connecting rod bearing grease cup- Hand fill as required. MIL-G-
10924A-GAA

Pump Reduction Gearcase- Check oil level daily- drain, flush and refill
case to level plug every 1, 000 running hours. EP90-140 (MIL-L-2105,
Grade 90)

Wheel Bearings - Sealed type ball bearing, no lubrication required.

18. Changing The Diaphragm (Fig. 4)

- A. With the pump body (B) drained, turn the engine starting pulley until the connecting rod is in its lowest position.
- B. Remove four bolts and nuts (G) holding pump body to the frame (C).
- C. Lift the combination pump top and frame upward as far as the holding chain will permit. The pump top and frame will position over-center and will be held in position by the holding chain. (Fig/ 7).
- D. The rubber diaphragm (D) is now fully exposed.
- E. Remove two 5/8" brass nuts (E) and remove diaphragm flange (F).
- F. Pull old rubber diaphragm (D) off pump. Clean the inner and outer diaphragm seating areas on pump with a steel brush.
- G. Position new rubber diaphragm (D) in place. Replace diaphragm flange (F) and secure with brass nuts (E). Tighten nuts (E) until diaphragm is slightly depressed. Remove preservative from new diaphragm.
- H. Swing the combination pump top and frame down to its normal position. Secure with the four bolts and nuts (G), taking up a like amount on each nut to equalize pressure on the rubber diaphragm edge.

19. Inlet Valve Repair (Fig. 3A)

The inlet valve is located at the inlet or suction side of the pump body, and is of the flap valve type. Depending on use and material pumped, wear will take place on Item (F), the rubber flap valve. Repair is as follows:

- A. With the suction line off (disconnected) and pump drained, or if working conditions permit, suction line may be left on the inlet valve, remove four 5, %" nuts and washers (V) from studs (A). Pull inlet valve free from pump body. Do not damage gasket (D). Save for reuse.
- B. Remove two brass screws (H), and keeper (G). Save for reuse. Remove two brass screws (C) with nuts and washers (X). Loosen and remove washer (E) and weight (J).
- C. With new rubber flap valve (F), reassemble flap valve assembly. Replace inlet valve assembly with gasket (D) on pump body and secure with the four 5/8" nuts and washers (V) on studs (A).

20. Discharge Valve Repair (Fig. 3A)

The discharge valve is located on the pump body opposite of the inlet valve and is of the flap valve type. Depending on use and material pumped, the rubber flap valve (N) will have to be replaced. Repair as follows:

- A. Remove four 5/8" hex nuts with washers (Y) from studs (U). Pull discharge valve body (S) off studs (U).

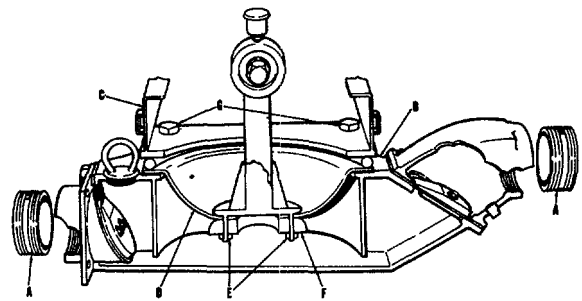

FIGURE 4
PUMP BODY AND ADJACENT PARTS

Reference for Fig. 4

- A. 4" Close Nipples
 - B. Pump Body
 - C. Frame
 - D. Rubber Diaphragm
 - E. 5/8" Brass Nuts
 - F. Diaphragm Flange
 - G. Bolts and Nuts
- B. Remove two brass nuts with washers (R) and two brass machine screws (K). Washer (L) and weight (P) may be pulled off rubber flap valve (N).
 - C. Replace flap valve (N). Assemble items (K) thru (R) and place on pump body over the studs. Place valve body on pump over studs and secure with the 5/8 " hex nuts.
- #### 21. Connecting Rod Needle Bearing Repair (Fig. 5)

The connecting rod (A) oscillates on the output shaft (B) of the reduction gearcase. Bearing replacement is as follows:

- A. Remove four bolts and nuts holding pump body to the frame. Reference Par. 18.
- B. Lift the pump top upward as far as the holding chain will permit. Block pump body in this position and remove rubber diaphragm. Ref. Par. 18.
- C. Remove cap screw (D) and keeper (E). Pull connecting rod (A) with bearing (C) off shaft.
- D. Press bearing (C) from bore of connecting rod. The grease cup (F) may be cleaned of any hard grease that may have accumulated. Repack grease cup. Ref. "Lubrication Chart."
- E. Press new bearing (C) into bore of connecting rod, then hand grease bearing.
- F. Replace connecting rod (A) with bearing (C) on shaft (B). Replace keeper (E) and tighten with cap screw (D). Hand turn grease cup cap down to force grease into bearing and grease channel. Refill grease cup to level.

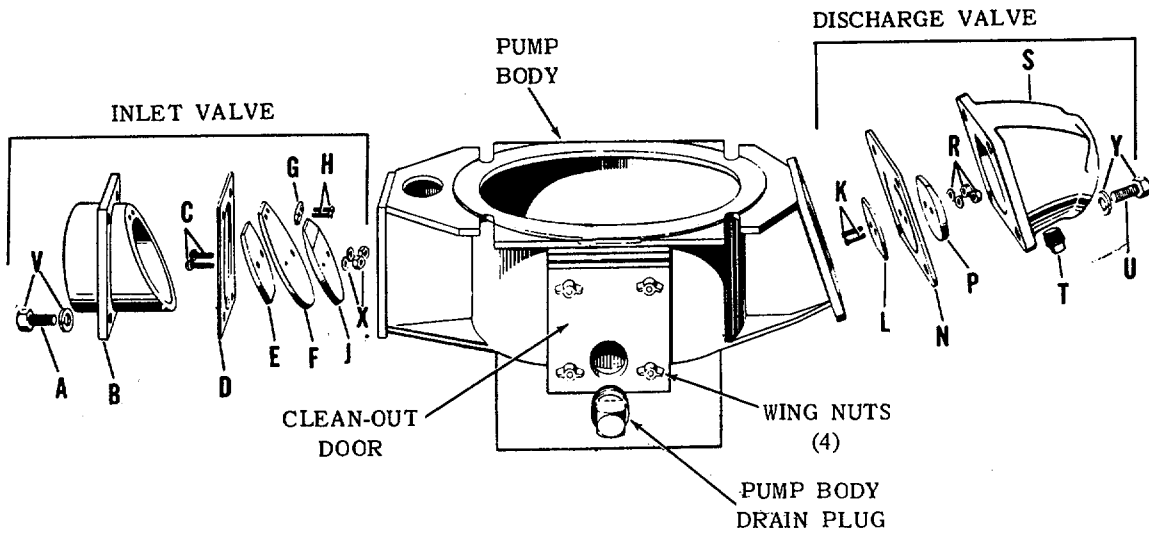

FIGURE 3A
PUMP BODY AND VALVES

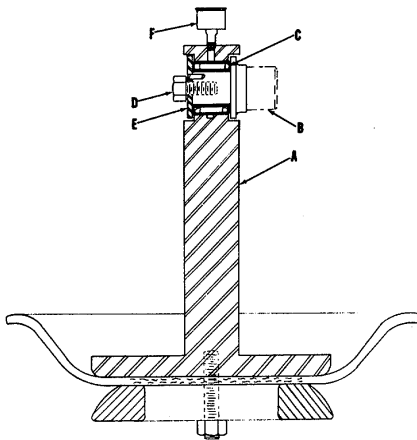

FIGURE 5
CONNECTING ROD

Reference for Fig.

- A. Studs $\frac{5}{8}$ "
- B. Inlet Valve Body
- C. Brass Screws
- D. Gasket
- E. Washer
- F. Rubber Flap Valve
- G. Keeper
- H. Brass Screws
- J. Weight
- K. Brass Machine Screws
- L. Washer
- N. Rubber Flap Valve
- P. Weight
- R. Brass Nuts and Washers
- S. Discharge Valve Body
- T. Discharge Valve Drain Plug
- U. $\frac{5}{8}$ " Studs
- V. $\frac{5}{8}$ " Nuts and Lock Washers
- X. Brass Nuts and Lock Washers
- Y. $\frac{5}{8}$ " Nuts and Lock Washers

Reference for Fig. 5

- A. Connecting Rod
- B. Output Shaft
- C. Bearings
- D. Cap Screw
- E. Keeper
- F. Grease Cup

-
- G. Replace rubber diaphragm. Ref. Par. 18. Lower pump top down. Secure pump top to frame with the four nuts and bolts.

22. Gearcase (pump side) Disassembly and Assembly - (Ref. Fig. 6 and 7)

The entire power unit and gear train should be removed from the pump frame for bench work.

- A. Drain oil from the reduction gearcase.
- B. Disconnect connecting rod. Refer to Par. 21.
- C. Ref. Fig. 6. Remove the two 1/2" bolts, lock washers and nuts (B) holding gearcase to the gearcase support. Ref. Fig. 7. Remove two bolts with lock washers and nuts (D), Fig. 7, holding engine to frame. Save shims (C) Fig. 6, and shims (E) Fig. 7 for reuse.
- D. Lift reduction case and engine off frame for bench work.
- E. Twelve 5/6" cap screws (F) holding the cover halves together. Remove these bolts and pull reduction case assembly (H) from intermediate section (J). Gasket (G) should be replaced new in reassembly.
- F. Pry out snap ring (K) and pull spur gear (L) off pinion shaft (U). The 1/4" straight key may be saved for reuse if not damaged.
- G. Remove three 5/16" socket head cap screws with lock washers (M) and retainer (N).
- H. Straighten ear of lock washer (P). Remove lock nut (O) and washer (P). Pull output shaft crank arm (Q) from housing (A). Retain gear (R) from falling. Remove key (S) and manipulate gear (R) from housing. Remove spacer (T).
- I. Pull pinion shaft (U) with bearings (V) and (W) from housing. Bearings (V) and (W) may be removed from pinion shaft.
- J. Remove the two round head screws and oil trap (X), and snap ring (Y).
- K. Bearing (Z) may be pulled from bore of housing. Pull out spacer (AA) and pull out bearing (B3B) from housing, and inner snap ring (Y).
- L. Assembly is in reverse of the above procedure.

23. Gearcase (engine side) Disassembly and Assembly (Ref. Fig. 6)

- A. Remove the V44" socket set screw and oil slinger (EE). Note position of oil slinger for reassembly to prevent damage to oil slinger.
- B. Remove five 1/4" cap screws with lock washers (DD). Housing (j), bearing retainer (FF), gaskets (GO), bearings (HH) and (JJ) with pinion shaft (KK) may now be pulled from housing (LL).
- C. Pull bearings (HH) and (JJ) off pinion shaft (KK).

- D. Remove cap screw (MM) with lock washer and special washer (NN) from engine shaft (OO). Pinion (PP) is grooved for removal with a puller. Remove pinion. Remove woodruff key (RR) from shaft (OO).
- E. Remove three cap screws (SS) and internal flat head cap screws (TT) from housing. Pull housing (LL) with gasket (UU) from engine housing.
- F. Clean and inspect all parts. All gaskets should be replaced with new ones.
- G. Assembly is in reverse of above procedure. Refer to lubrication chart for filling reduction case.

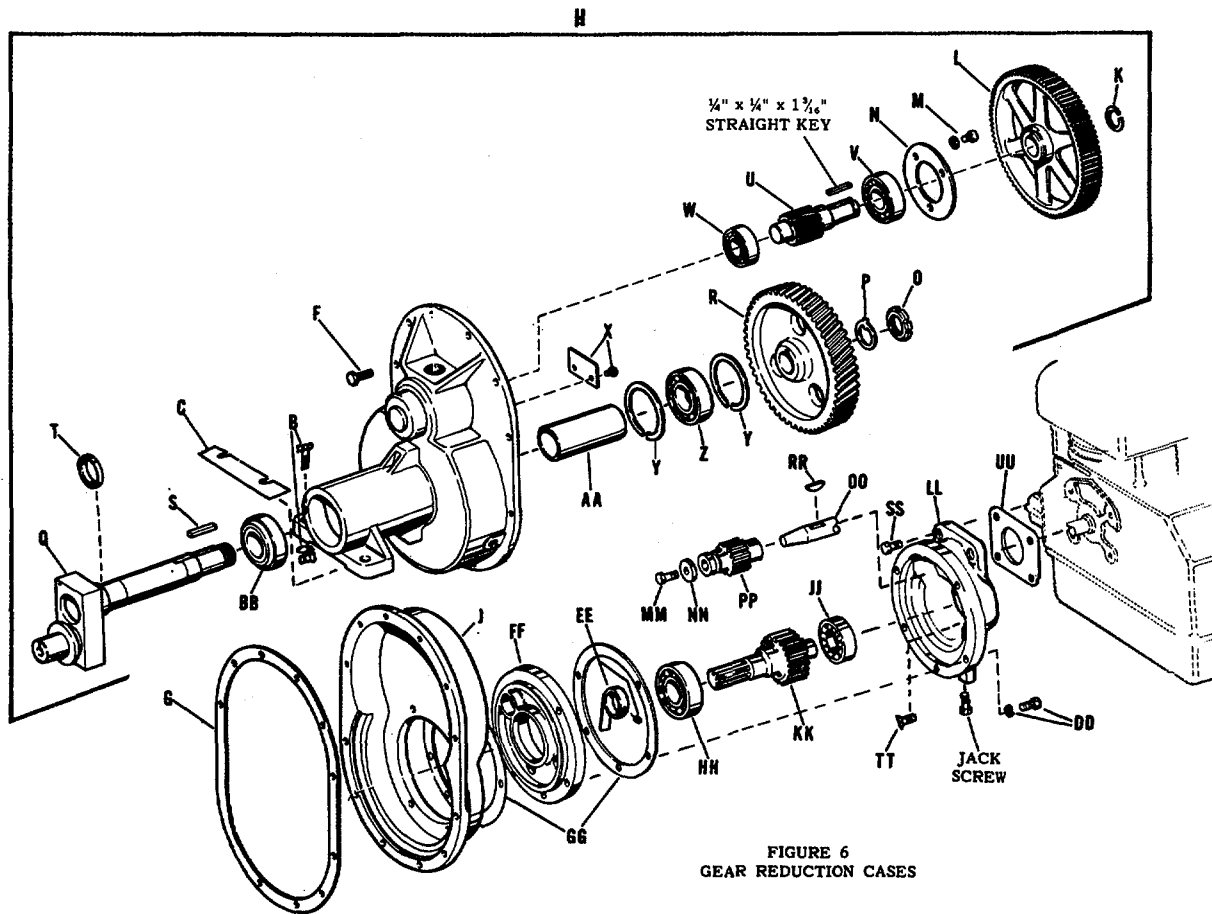

FIGURE 6
GEAR REDUCTION CASES

FIGURE 6

Reference for Fig. 6

- A. Housing
- B. Bolts 1/2" w/Nuts and L.W.
- C. Shims
- F. Cap Screws 5/16"
- G. Gasket
- H. Reduction Case Assembly
- J. Intermediate Section
- K. Snap Ring
- L. Spur Gear
- M. 5/16" Socket Hd. C.S. w/L.W.
- N. Retainer
- O. Lock Nut
- P. Lock Washer
- Q. Output Shaft Crank Arm
- R. Gear
- S. Key, Straight
- T. Spacer
- U. Pinion Shaft
- V. Bearing
- W. Bearing
- X. Oil Trap w/Screws
- Y. Snap Ring
- Z. Bearing

- AA. Spacer
- BB. Bearing
- DD. C.S. 3/8" w/L.W.
- EE. Oil Slinger w/Set Screws 1/4"
- FF. Bearing Retainer
- GG. Gasket
- HH. Bearing
- JJ. Bearing
- KK. Pinion Shaft
- LL. Housing
- MM. Cap Screw
- NN. Special Washer
- OO. Engine Shaft
- PP. Pinion
- RR. Woodruff Key
- SS. Cap Screw
- TT. Flat Hd. Cap Screw
- UU. Gasket

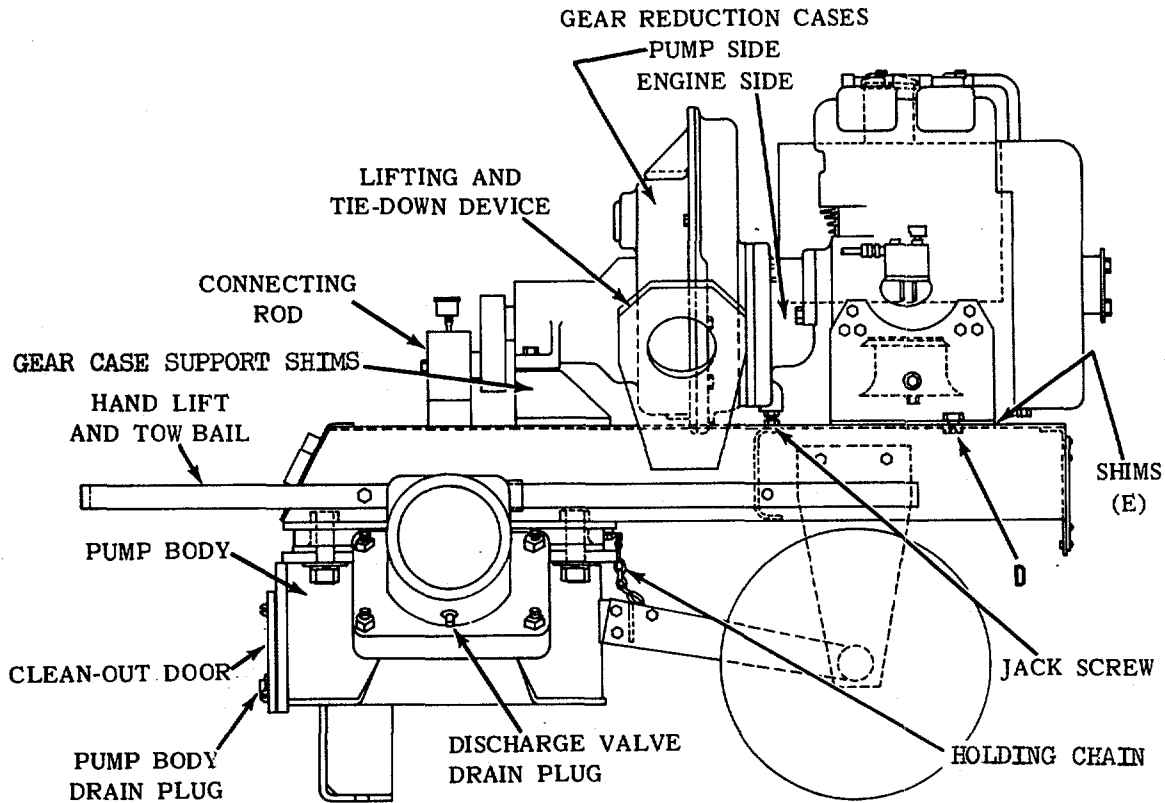

FIGURE 7
DISCHARGE SIDE OF PUMP

24. Wheels (Fig. 8)

The wheels are equipped with a cushion type tire (non-pneumatic) and contain two sealed type ball bearings at the hub. Bearings are pregreased and sealed.

To remove the wheel, remove the 1/4" x 2 1/4" machine bolt with nut and lock washer (A). Pull off cap (B) and washer or washers (C). Pull wheel off axle.

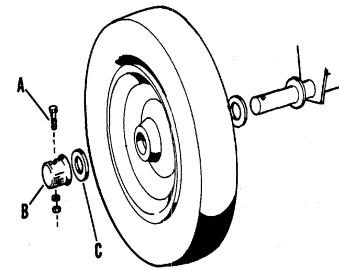

FIGURE 8
WHEEL HUB ASSEMBLY

25. Lifting and Tie Down (Ref. Fig. 7)

The diaphragm pump is equipped with two combination of gravity tition lifting and tie down eyes located at the center of the pump.

Reference for Fig. 8

- A. Machine Bolt w/Nut & L.W.
- B. Cap
- C. Washer

APPENDIX A

BASIC ISSUE ITEMS LIST

Section I. INTRODUCTION

A-1. Scope

This appendix lists items which accompany the reciprocating pump or are required for installation, operation, or operator's maintenance,

A-2. General

This Basic Issue Items List is divided into the following sections:

- a. Basic Issue Items -Section II. A list of items which accompany the reciprocating pump or are required for the installation, operation, or operator's maintenance.
- b. Maintenance and Operating Supplies - Section III. A listing of maintenance and operating supplies required for initial operation.

A-3. Explanation of Columns

The following provides an explanation of columns in the tabular list of Basic Issue Items, Section II,

- a. Source, Maintenance, and Recoverability Codes (SMR), Column 1:

(1) Source Code indicates the selection status and source for the listed item. Source code is:

Code	Explanation
P	Applied to repair parts which are stocked in or supplied from GSA/DSA or Army supply system, and authorized for use at indicated maintenance categories.

(2) Maintenance Code indicates the lowest category of maintenance authorized to install the listed item, The maintenance level code is:

Code	Explanation
C	Operator/crew

- b. Federal Stock Number, Column 2. This column indicates the Federal stock number for the item.

- c. Description, Column 3. This column indicates the Federal item name and any additional description of the item required. A part number or other reference number is followed by the applicable five-digit Federal supply code for manufacturers in parentheses.
- d. Unit of Issue, Column 4. This column indicates the unit used as a basis for issue, e.g., ea, pr, ft, yd, 3tc.
- e. Quantity Incorporated in Unit Pack, Column 5. This column not applicable.
- f. Quantity Incorporated In Unit, Column 6. This column indicates the quantity of the item used in the functional group.
- g. Quantity Furnished with Equipment, Column 7. This column indicates the quantity of an item furnished with the equipment.
- h. Quantity Authorized, Column 8. This column indicates the quantity of an item authorized the operator/crew to have on hand or to obtain as required. As required items are indicated with an asterisk.
- i. Illustration, Column 9. This column not applicable.

A-4. Explanation of Columns in the Tabular List of Maintenance and Operating Supplies -- Section III.

- a. Item, Column 1. This column lists numerical sequenced item numbers assigned to each component application to facilitate reference.
- b. Component Application, Column 2. This column identifies the component application of each maintenance or operating supply item.
- c. Federal Stock Number, Column 3. This column indicates the Federal stock number for the item and will be used for requisitioning purposes.
- d. Description, Column 4. This column indicates the item and brief description.
- e. Quantity Required for Initial Operation, Column 5. This column indicates the quantity of each maintenance or operating supply item required for initial operation of the equipment.
- f. Quantity Required for 8 Hours Operation, Column 6. This column indicates estimated quantities required for an average eight hours of operation.

g. Notes, Column 7: This column indicates informative notes keyed to data appearing in preceding column.

A-5. Federal Supply Code for Manufacturers

Code

Manufacturer

97403

Army Engineer Research and Development Laboratories Fort Belvoir, Va.

SECTION II

BASIC ISSUE ITEMS LIST

(1) SOURCE, MAINT, AND RECOV CODE			(2) FEDERAL STOCK NO.	(3) DESCRIPTION	(4) UNIT OF ISSUE	(5) QTY INC IN UNIT PACK	(6) QTY INC IN UNIT	(7) QTY FURN WITH EQUIP	(8) QTY AUTH	(9) ILLUSTRATION	
(A) S	(B) M	(C) R								(A) FIG NO.	(B) ITEM NO.
				Group 31 - BASIC ISSUE ITEMS MANUFACTURER OR DEPOT INSTALLED							
				3100 - BASIC ISSUR ITEMS MANUFACTURER OR DEPOT INSTALLED							
P	C		7520-559-9618	CASE,COTTON DUCK: Maintenance and operating Equipment Manuals	EA			1	1		
P	C		2990-972-7950	ROPE,STARTING 9786E121 (97403)	EA			1	1		
				DEPARTMENT OF THE ARMY TECHNICAL MANUALS TM 5-2805-257-14 and TM 5-4320-252-14	EA			1	1		
				3200 - BASIC ISSUE ITEMS TROOP INSTALLED							
P	C		4210-555-8837	EXTINGUISHER,FIRE,HAND, MONOBROMOTRI- FLUOROMETHANE, W/BRACKET	EA			0	*		
				A-4							

SECTION III

MAINTENANCE AND OPERATING SUPPLIES

(1) ITEM	(2) COMPONENT APPLICATION	(3) FEDERAL STOCK NUMBER	(4) DESCRIPTION	(5) QUANTITY REQUIRED F/INITIAL OPERATION	(6) QUANTITY REQUIRED F/8 HRS OPERATION	(7) NOTES
1	0306 Fuel Tank	9130-160-1818	GASOLINE, AUTOMOTIVE, COM- BAT, BULK.	1.5 gal.	2.7 gal.	Average fuel consumption 0.35 GPHE.
2	5507 Pup Drive	9150-577-5844	OIL, LUBRICATING, GEAR: MIL-L-2105, Grade 90.5 gal. Drum	2 pt.	0.25 pt.	
3	5508 Lubrication	9150-190-0904	GREASE, AUTOMOTIVE AND ARTILLERY: MIL-G-10924-GAA 1 lb. can A-5	0.25 lb.	0.125 lb.	

APPENDIX B

MAINTENANCE ALLOCATION CHART

Section 1. INTRODUCTION

B-1. General

a. This section provides a general explanation of all maintenance and repair functions authorized at various maintenance and repair functions authorized at various maintenance levels.

b. Section II designates overall responsibility for the performance of maintenance functions on the identified end item or component. The implementation of the maintenance functions upon the end item or component will be consistent with the assigned maintenance functions.

c. Section III Not Applicable

d. Section IV contains supplemental instructions, explanatory notes and/or illustrations required for a particular maintenance function.

B-2. Explanation of Columns in Section II

a. Group Number, Column 1. The functional group is a numerical group set up on a functional basis. The applicable functional grouping indexes (obtained from TB 750-93-1, Functional Grouping Codes) are listed on the MAC in the appropriated numerical sequence. These indexes are normally set in accordance with their function and proximity to each other.

b. Functional Group, Column 2. This column contains a brief description of the components of each functional group.

c. Maintenance Functional, Column 3. This column lists the various maintenance functions (A through K) and indicates the lowest maintenance category authorized to perform these functions. The symbol designations for the various maintenance categories are as follows:

- C - Operator or crew
- O - Organizational maintenance
- F - Direct support maintenance
- H - General support maintenance
- D - Depot maintenance

The maintenance functions are defined as follows:

- A - INSPECT. To determine serviceability of an item by comparing its physical, mechanical, and electrical characteristics with established standards.
 - B - TEST. To verify serviceability and to detect electrical or mechanical failure by use of test equipment.
 - C - SERVICE. To clean, to preserve, to charge, to paint, and to add fuel, lubricants, cooling agents, and air.
 - D - ADJUST. To rectify to the extent necessary to bring into proper operating range.
 - E - ALIGN. To adjust specified variable elements of an item to bring to optimum performance.
 - F - CALIBRATE. To determine the corrections to be made in the readings of instruments or test equipment used in precise measurement, Consists of the comparisons of two instruments one of which is a certified standard of known accuracy, to detect and adjust any discrepancy in the accuracy of the instrument being compared with the certified standard,
 - G - INSTALL. To set up for use in an operational environment such as an emplacement, site, or vehicle.
 - H - REPLACE, To replace unserviceable items with serviceable assemblies, subassemblies, or parts.
 - I - REPAIR. To restore an item to serviceable condition, This includes, but is not limited to, inspection, cleaning, preserving, adjusting. replacing, welding, riveting, and strengthening,
 - J - OVERHAUL. To restore an item to a completely serviceable condition as prescribed by maintenance serviceability standards using the Inspect and Repair Only as Necessary (IROAN) technique,
 - K - REBUILD. To restore an item to a standard as nearly as possible to original or new condition in appearance, performance, and life expectancy. This is accomplished through complete disassembly of the item, inspection of all parts or components, repair or re-placement of worn or unserviceable elements (items) using original manufacturing tolerances and specifications, and subsequent reassembly of the item.
- d. Tools and Equipment, Column 4. This column is provided for referencing by code the special tools and test equipment, (Section III) required to perform the maintenance functions (Section II).

NONE USED

- e. Remarks, Column 5. This column is provided for referencing by code the remarks (Section IV) pertinent to the maintenance functions.

B-3. Explanation fo Columns in Section IV

- a. Reference Code. This column consists of two letters separated by a dash, both of which are references to Section II, The first letter references column 5 and the second letter references a maintenance function,

column 3, A through K.

b. Remarks. This column lists information pertinent to the maintenance function being performed, as indicated on the MAC, Section II.

B-3

SECTION II - MAINTENANCE ALLOCATION CHART

(1) GROUP NO.	(2) FUNCTIONAL GROUP	(3) MAINTENANCE FUNCTIONS											(4) TOOLS AND EQUIPMENT	(5) REMARKS			
		A	B	C	D	E	F	G	H	I	J	K					
		INSPECT	TEST	SERVICE	ADJUST	ALIGN	CALIBRATE	INSTALL	REPLACE	REPAIR	OVERHAUL	REBUILD					
01	ENGINE																
0100	Engine Assembly	C	0	C					F	F	H						A
03	FUEL SYSTEM																
0306	Tanks, Lines, Fittings			C					0								
11	REAR AXLE																
1100	Rear Axle Assembly								0	F							
13	WHEELS																
1311	Wheel Assembly									0							
15	FRAME																
1501	Frame Assembly									F							
1503	Towing Attachments								0	F							

SECTION II - MAINTENANCE ALLOCATION CHART

(1) GROUP NO.	(2) FUNCTIONAL GROUP	(3) MAINTENANCE FUNCTIONS											(4) TOOLS AND EQUIPMENT	(5) REMARKS		
		A	B	C	D	E	F	G	H	I	J	K				
		INSPECT	TEST	SERVICE	ADJUST	ALIGN	CALIBRATE	INSTALL	REPLACE	REPAIR	OVERHAUL	REBUILD				
22	ACCESSORY ITEMS															
2202	Hoses	C							C							
2210	Data Plates								O							
55	PUMPS															
5500	Pump Assembly	C		C						F	H					
5502	Rods, Bearings, Diaphragm	C		O					O							
5505	Suction and Discharge Assy.	C		C					O							
5507	Pump Drive: Reduction Gear Case			O						F	H					
5508	Lubrication	C		O					O							

Section IV. REMARKS

REFERENCE CODE	REMARKS
A	Refer to TM 5-2805-257-14 and TM 5-2805-257-24P for ENGINE MAINTENANCE AND REPAIR

APPENDIX C

REPAIR PARTS AIIID SPECIAL TOOLS LIST

Section I. INTRODUCTION

C-1. Scope

This appendix lists repair parts and special tools required for the performance of organizational, direct support, general support maintenance of the reciprocating pump.

C-2. General

a. The repair parts list is arranged as follows:

(1) Individual parts and major assemblies are listed alphabetically by item name within the numbered functional groups.

(2) Assembly components and subassemblies are indented and listed alphabetically by item name under major assemblies.

b. This Repair Parts and Special Tools List is divided into the following sections:

(1) Prescribed Load Allowance (PLA) - Section II. A consolidated listing of repair parts quantitatively allocated for initial stockage at the organizational level. This is a mandatory minimum stockade allowance.

(2) Special Tools, Test and Support Equipment - Section III. A list of special tools, test and support equipment authorized for the performance of maintenance at the organizational level. Not applicable.

(3) Repair Parts - Section IV. A list of repair parts authorized for the performance of maintenance at the organizational level.

(4) Repair Parts - Section V. A list of repair parts authorized for the performance of maintenance at the direct support, general support level.

(5) Special Tools Test and Support Equipment - Section VI. A list of special tools, test and support equipment authorized for the performance of maintenance at the direct support, general support level. Not applicable.

(6) Federal Stock Number and Reference Number Index- -Section VII. A list of Federal stock numbers followed by reference numbers, appearing in all the listings, in ascending alphanumeric sequence cross-referenced to index number.

C-3. Explanation of Columns

The following provides an explanation of columns in the tabular lists in sections II through VI

a. Source, Maintenance, and Recoverability Codes (SMR).

Note. Common hardware items known to be readily available in Army supply channels will be assigned Maintenance codes only. Source codes, Recoverability codes, and Maintenance Allowances will not be assigned to this category,

- (1) Source Code. Indicates the selection status and source for the listed item. Source codes used are:

Code	Explanation
P	Applied to repair parts which are stocked in or supplied from DS./GSA or Army supply system, and authorized for use at indicated categories.
M	Applied to repair parts which are not procured or stocked but are to be manufactured at indicated maintenance categories.
A	Applied to assemblies which are not procured or stocked as such but made up of two or more units, each of which carry individual stock numbers and descriptions and are procured and stocked and can be assembled by units at indicated maintenance categories.
X	Applied to parts and assemblies which are not procured or stocked, the mortality of which is normally below that of the applicable end item, and the failure of which should result in retirement of the end item from the supply system.
X1	Applied to repair parts which are not procured or stocked, the requirement for which will be supplied by use of the next higher assembly or components.
X2	Applied to repair parts which are not stocked. The indicated maintenance category requiring such repair parts will attempt to obtain them through cannibalization; if not obtainable through cannibalization, such repair parts will be requisitioned with supporting justification through normal supply channels.
C	Applied to repair parts authorized for local procurements. If not obtainable from local procurement, such repair parts will be requisitioned through normal supply channels with a supporting statement of nonavailability from local procurement.
G	Applied to major assemblies that are procured with PEMA (Procurement Equipment Missile Army) funds for initial issue only to be used as exchange assemblies at DSU and GSU maintenance level. These assemblies will not be stocked above DSU and GSU level or returned to depot supply level.

(2) Maintenance Code. Indicates the lowest category of maintenance authorized to install the listed item. The maintenance level codes are:

Code	Explanation
O	Organizational maintenance
F	Direct support maintenance
H	General support maintenance

(3) Recoverability Code. Indicates whether unserviceable items should be returned for recovery or salvage. Items not coded are expendable. Recoverability codes are:

Code	Explanation
R	Applied to repair parts and assemblies which are economically repairable at DSU and OSU activities and normally are furnished by supply on an exchange basis.
T	Applied to high dollar value recoverable repair parts which are subject to special handling and are issued on an exchange basis. Such repair parts normally are repaired or overhauled at depot maintenance activities.
U	Applied to repair parts specifically selected for salvage by reclamation units because of precious metal content, critical materials, high dollar value reusable casings or castings.

(4) This column also lists, below the SMR code, an index number for each item in ascending numerical sequence, which is used to locate items in the publication when the Federal stock number and/or reference number is known.

b. Federal Stock Number. Indicates the Federal stock number for the item.

c. Description. Indicates the Federal item name and army additional description of the item required. A, part number or other reference number is preceded by the applicable five-digit Federal supply code for manufacturers in parentheses.

d. Unit of Issue. Indicates the unit used as a basis for issue, e.g., ea, pr, ft, yd, etc.

e. Quantity Incorporated in Unit Pack. Indicates the actual quantity contained in the unit pack.

f. Quantity Incorporated in Unit, Indicates the quantity of the item used in the functional group.

g. Fifteen-Day Organizational Maintenance Allowances.

(1) The allowance columns are divided into four subcolumns. Indicated in each subcolumn opposite the first appearance of each item is the total quantity of items authorized for the number of equipments supported. Subsequent appearances of the same item will have no entry in the allowance columns but will have in the description column a reference to the first appearance of the item. Items authorized for use as required but not for initial stockage are identified with an asterisk in the allowance column,

(2) The quantitative allowances for organizational level of maintenance represents one initial prescribed load for a 15-day period for the number of equipments supported, Units and organizations authorized additional prescribed loads -will multiply the number of prescribed loads authorized by the quantity of repair parts reflected in the appropriate density column to obtain the total quantity of repair parts authorized.

(3) Organizational units providing maintenance for more than 100 of these equipments shall determine the total quantity of parts required by converting the equipment quantity to a decimal factor by placing a decimal point before the next to last digit of the number to indicate hundredths, and multiplying the decimal factor by the parts quantity authorized in the 51-100 allowance column. Example, authorized allowance for 51-100 equipments is 12; for 140 equipments multiply 12 by 1.40 or 16.80 rounded off to 17 parts required.

(4) Subsequent changes to allowances will be limited as follows: No change in the range of items is authorized. If additional items are considered necessary, recommendation should be forwarded to U. S. Army Mobility Equipment Command for exception or revision to the allowance list. Revisions to the range of items authorized will be made by this Command based upon engineering experience, demand data, or TAERS information.

h. Thirty-Day D/GS Maintenance Allowances.

(1) The allowance columns are divided into three subcolumns. Indicated in each subcolumn, opposite the first appearance of each item, is the total quantity of items authorized for the number of equipments supported. Subsequent appearances of the same item will have no entry in the allowance column, but will have in the description column a reference to the first appearance of the item. Items authorized for use as required but not for initial stockage are identified with an asterisk in the allowance column.

(2) The quantitative allowances for DS/GS levels of maintenance will represent initial stockage for a 30-day period for the number of equipments supported.

(3) Determination of the total quantity of parts required for maintenance of more than 100 of these equipments can be accomplished by converting the equipment quantity to a decimal factor by placing a decimal point before the next to last digit of the number to indicate hundredths, and multiplying the decimal factor by the parts quantity authorized in the 51-100 allowance column. Example, authorized allowance for 51-100 equipments is 40; for 150 equipments multiply 40 by 1,50 or 60 parts required.

i. One-Year Allowances Per 100 Equipments/Contingency Planning Purposes. Indicates opposite the first appearance of each item the total quantity required for distribution and contingency planning purposes. The range of items indicates total quantities of all authorized items required to provide for adequate support of 100 equipments for one year.

i. Illustration

(1) Figure Number. Indicates the figure number of the illustration in which the item is shown

(2) Item Number. Indicates the callout number used to reference the item in the illustration.

C-4. Special Information

a. Repair parts for the gasoline engine, FSN 2805-072-4871 model 2A016-111 are not contained herein. See TM 5-2805-257-24P.

b. Repair parts mortality has been based on 3000 hours of operation per year.

c. Parts which require manufacture or assembly at a category higher than that authorized for installation will indicate in the source column the higher category.

d. The following publication pertains to the reciprocating pump and its components: TM 5-2805-257-14 and TM 5-2805-257-24P Engine, Gasoline: Military Standard Models (Model 1A08-111) 1½ HP, (Model 2A016-LI.) 3 HP.

C-5. How to Locate Repair Parts

a. When Federal stock number or reference number is unknown:

(1) First. Using the table of contents, determine the functional group or subgroup within which the repair part belongs. This will refer to a page in the parts listing.

(2) Second. The illustration column of the page: refers to a figure number.

(3) Third. Locate the figure and identify the repair parts, noting the item number.

(4) Fourth. Refer back to the page of the parts listing. Find the item number in the illustration column that corresponds with the figure number.

b. Then Federal stock number or reference number is known:

(1) First Using the Index of Federal Stock Numbers and Reference Numbers, find the pertinent Federal stock number or reference number. This index is in ascending alpha-numeric sequence cross-referenced to an index number,

(2) Second. Using the Repair Parts Listing, find the index number reference in the Index of Federal Stock Numbers and Reference Numbers.

C-6. Abbreviations

Abbreviations	Explanation
dia	diameter
mtg	mounting
sq	square
thd	thread
w	wide

C-7. Federal Supply Codes for Manufacturers

Code	Manufacturer
21335	Fanfare Bearing Co.
53786	Rex Chainbelt Inc. Construction Machinery Division
54275	Shadbolt and Boyd Co.
60399	Torrington Mfg. Co,
78252	Stolper Industries Inc,
80749	United Specialties Co,
81349	Military Specifications Promulgated by Standardization Div. Directorate of Logistics Services DSA
81910	Eaton Mfg. Co,
97403	Army Engineer Research and Development Laboratories

C-8. Recommendations for Maintenance Manual Improvements

Report of errors, omissions, and recommendations for improving this manual by the individual user is encouraged. Reports should be submitted

on a DA Form 2028 (Recommended Changes to DA Publications) and forwarded direct to commanding General U.S. Army Mobility Equipment Command, ATTN: AMSME-MPP, 4300 Goodfellow Boulevard, St. Louis, Missouri 63120.

C-7

SECTION II

PRESCRIBED LOAD ALLOWANCE

(1) FEDERAL STOCK NUMBER	(2) DESCRIPTION	(3) QTY INC IN UNIT PACK	(4) 15-DAY ORG MAINT. ALW			
			(A)	(B)	(C)	(D)
			1-5	6-20	21-50	51-100
	0107 - ENGINE STARTING SYSTEMS					
2990-972-7950	ROPE, STARTING: engine (97403) 9786E121				2	2
	5500 - PUNPS ASSEMBLY					
4320-724-1360	GASKET, DOOR CLEANOUT (53786) 84624			2	2	3
	5502 - RODS, BEARINGS, DIAPHRAGM					
3110-112-6026	BEARING, NEEDLE: pump shaft (60399) BR2020					2
4320-730-5905	DIAPHRA4GM, RUBBER (53786) X5062				2	2
5315-985-4432	PIN, DOWEL: rod mtg					2
	5505 - SUCTION AND DISCHARGE ASSEMBLY					
4320-724-1359	FLAP: Inlet valve (53786) 62281					2
4320-724-1361	FLAP: discharge valve (53786) 101-3581-1					2
4320-725-1803	VALVE, INLET (53786) 265244A					2
4320-728-7395	GASKEL, INLET VALVE (53786) 84622			2	2	3

(1) SMR CODE	(2) FEDERAL STOCK NUMBER	(3) DESCRIPTION REFERENCE NUMBER & MFR CODE USABLE ON CODE		(4) UNIT OF ISSUE	(5) QTY INC IN UNIT	(6) QTY INC IN UNIT	(7) 15-DAY ORGANIZATIONAL MAINTENANCE ALW				(8) ILLUS- TRATION	
							(a) 1-5	(b) 6-20	(c) 21-50	(d) 51-100	(a) FIGURE NO.	(b) ITEM NO.
00001		SECTION III - REPAIR PARTS FOR ORGANIZATIONAL MAINTENANCE										
00003-00015		GROUP 01 - ENGINE 0107 - ENGINE STARTING SYSTEMS										
P 0 00016	2990-972-7950	ROPE, STARTING: ENGINE (97403) 9786E121		EA	1	1	*	*	2	2		
00016 00017		GROUP 03 - FUEL SYSTEM 0306 - TANKS, LINE, FITTINGS										
X20 00018		FELT, FUEL TAN (54275) 1-8X1X221-2LG		EA		2					C4	22
P 0 00019	2910-717-3790	FUEL TANK (54275) 102-3583-1		EA		1	*	*	*	*	C4	20
P O 00020	2910-717-3792	CAP: FUEL TANK, WITH GASKET (78252) 23O2J012		EA		1	*	*	*	*	C4	18
P O 00021		STRAINER: FUEL TANK (78252) 23438051		EA		1	*	*	*	*	C4	19
P 0 00022	2910-724-1423	LINE ASSEMBLY, FUEL (53786) 502-2674-80		EA		1	*	*	*	*	C4	24
P 0 00023	4730-349-4276	NIPPLE, SPECIAL: 1/8 IN. 53786) 298-12011-86		EA		2	*	*	*	*	C4	23
0 00024	5310-O50-6652	NUT, PLAIN, HEXAGON: TANK MTG, 3/8-16 THO SIZE		EA		4					C4	16
X20 00025		STRAP, FUEL TANK MOUNTING (53786) 502-2673-80		EA		2					C4	21
0 00026	5310-534-370-	WASHER, LOCK: TANK MTG, 3/8 IN. SCREW SIZE		EA		4					C4	17

(1) SMR CODE	(2) FEDERAL STOCK NUMBER	(3) DESCRIPTION REFERENCE NUMBER & MFR CODE USABLE ON CODE		(4) UNIT OF ISSUE	(5) QTY INC IN UNIT	(6) QTY INC IN UNIT	(7) 15-DAY ORGANIZATIONAL MAINTENANCE ALW				(8) ILLUS- TRATION	
							(a) 1-5	(b) 6-20	(c) 21-50	(d) 51-100	(a) FIGURE NO.	(b) ITEM NO.
00035 00036 X20 00037 0	5310-543-5626	GROUP 13 - WHEELS 1311 - WHEEL A5SEMBLY CAP, HUB (53786) 61844A		EA		2					C4	38
00038 0	5305616-6370	NUT, PLAIN, HEXAGON: HUB CAP MTG, 1/4-20 THD SIZE		EA		2					C4	25
00039 X20 00040 0	5310-812-103	SCREW, CAP, HEXAGON HEAD: HUB CAP trig, 1/400 THD SIZE, 1 3/4 IN.LG WASHER, AXLE (53786) 61860		EA		2					C4	37
00041 X20 00042 00043 00056 X20 00057 0	5310-050-6652	WA5HER, LOCK: HUB CAP MTG, 1/4 IN.SCREW SIZE		EA		2					C4	26
00058 0	5305-862-6901	WHEEL, SEMIPNEUMATIC TIRE (53786) 298-4045-47		EA		2					C4	36
00060 0 00061	5310-534-3703	GROUP 15 - FRE 1503 - TOWING ATTACHMENTS BAIL, TOWING (53786) 266029		EA		1					C4	27
	5310-050-6652	NUT, PLAIN, HEXAGON: BAIL MTG, 3/8-16 THD SIZE		EA		2					C4	16
	5305-862-6901	SCREW, CAP, HEXAGON HEAD: BAIL MTG, 3/8-16 THD SIZE, 1 IN, LG		EA		2					C4	29
	5310-534-3703	WASHER, FLAT: BAIL MTG, 3/8 IN. SCREW SIZE		EA		2					C4	17
	5310-122-5606	WASHER, LOCK: BAIL MTG, 3/8 IN. SCREW SIZE		EA		2					C4	28

(1) SMR CODE	(2) FEDERAL STOCK NUMBER	(3) DESCRIPTION REFERENCE NUMBER & MFR CODE USABLE ON CODE		(4) UNIT OF ISSUE	(5) QTY INC IN UNIT	(6) QTY INC IN UNIT	(7) 15-DAY ORGANIZATIONAL MAINTENANCE ALW				(8) ILLUS- TRATION	
							(a) 1-5	(b) 6-20	(c) 21-50	(d) 51-100	(a) FIGURE NO.	(b) ITEM NO.
00062 00063		GROUP 22 - ACCESSORY ITEMS 2202 _- HOSES										
P 0 00064	4720-202-8653	HOSE, WATER: SUCTION (81349) ZZH561TYPE1		EA		4	*	*	*	*	C2	2
0 00065	4730-2-7130	NIPPLE, PIPE: INLET VALVE TO HOSE, 4 IN. DIA, 6 IN. LG		EA		2					C2	1
000066 0 00067	5310-167-1364	2210 - DATA PLATES NUT, PLAIN, HEXAGON: PLATE MTG, NO. 6 SCREW SIZE		EA		8					C4	13
X20 00068		PLATE, IDENTIFICATION: U.S. DEPARTMENT OF THE ARMY (53786) 102-7701-1		EA		1					C4	11
X20 00069		PLATE, IDENTIFICATION: TRANSPORTATION DATA (53786) 102-7700-1		EA		1					C4	10
0 00070	5305-010-0145	SCREW, MACHINE: PLATE MTG, NO. 6-32 THD SIZE, 3/8 ,IN. LG		EA		8					C4	9
0 00071	5310-514-6612	WASIER, LOCK: PLATE MTG NO. 6 SCREW SIZE		EA		8					C4	12
00072 00073		GROUP 55 - PUMPS 5500 - PUMPS ASSEMBLY										
P 00075	4320-725-1805	CAP, LIFT, PRIME PLUG (53786) 58669A		EA		1	*	*	*	*	C2	3
X20 00076		D00R, CLEANOUT (53786) 102-3570		EA		1					C2	17
P 0 00077	4320-724-1360	GASKET, D00R CLEANOUT (53786) 84624		EA		1	*	2	2	3	C2	19

(1) SMR CODE	(2) FEDERAL STOCK NUMBER	(3) DESCRIPTION		(4) UNIT OF ISSUE	(5) QTY INC IN UNIT	(6) QTY INC IN UNIT	(7) 15-DAY ORGANIZATIONAL MAINTENANCE ALW				(8) ILLUS- TRATION	
		REFERENCE NUMBER & MFR CODE	USABLE ON CODE				(a) 1-5	(b) 6-20	(c) 21-50	(d) 51-100	(a) FIGURE NO.	(b) ITEM NO.
0 00078	5310-720-8393	NUT, PLAIN, WING: C1EAN0UT D00R, 1/2-13 TH0 SIZE		EA		4					C2	15
0 00079.	4730-278-3363	P1UG, PIPE: CLEANOUT COVER, 1-11 1/2 THD SIZE		EA		1					C2	18
0 00080	5307-261-0354	STUD, PLAIN: CLEANOUT COVER NTG, 1/2-13 THD SIZE, 1 3/4 0N. LG		EA		4					C2	16
00081 P 0	3110-112-6026	5502 - R0DS, BEARINGS, DIAPHRAGM BEARING, NEEDLE: PUMP SHAFT (60399) BR2020		EA		1	*	*	*	2	C1	7
00082 X20		DIAPHRAGM ASSEMB1Y, RUBBER (53786) B83210		EA		1						C1
00083 P 0	4320-730-5905	DIAPHRAGM, RUBBER (53786) x50062		EA		1	*	*	2	2	C1	5
00084 P 0	4320-725-1784	FLANGE. DIAPHRAGM (53786) 60208A		EA		1	*	*	*	*	C1	4
00085 0	5310-011-5776	NUT, PLAIN, HEXAG0N: DIAPHRAGM MTG, BRASS, 5/8-11 THD SIZE		EA		2					C1	2
00086 X20	(R0D, CONNECTING 53786) A79520		EA		1					C1	6
00087 0		5307-261-0381	STUD, PLAIN: DIAPHRAGM MTG, 5/8-11 THD SIZE, 3 1/4 IN. LG		EA		2	C1	3			
00088 P 0	5315-985-4432	PIN, D0WEL: R0D MTG		EA		1	*	*	*	2	C1	8
00089 0	5305-558-3692	SCREW, CAP, HEXAG0N HEAD: R0D MTG, 1/2-13 THD SIZE, 1 IN. LG		EA	1					C1	10	
00090 P 0	4320-728-7394	WASHER, BEARING, RETAINER (53786) 61893		EA		1	*	*	*	*	C1	12
000091 0 00092	5310-010-6500	WASHER, 10CK: R0D MTG, 1/2 IN. SCREW SIZE		EA		1					C1	11

(1) SMR CODE	(2) FEDERAL STOCK NUMBER	(3) DESCRIPTION REFERENCE NUMBER & MFR CODE USABLE ON CODE		(4) UNIT OF ISSUE	(5) QTY INC IN UNIT	(6) QTY INC IN UNIT	(7) 15-DAY ORGANIZATIONAL MAINTENANCE ALW				(8) ILLUS- TRATION		
							(a) 1-5	(b) 6-20	(c) 21-50	(d) 51-100	(a) FIGURE NO.	(b) ITEM NO.	
00093 X20 - 00094 P 0	4320-724-1361	5505 - SUCTION AND DISCHARGE ASSEMBLY BODY, DISCHARGE VALVE (53786) 290542A		EA		1	C2	6					
00095 P 0		4320-728-7395	FLAP: DISCHARGE VALVE (53786) 101-3581-1		EA		1	*	*	*	2	C2	12
00096 0	5310-011-5776	GASKET, INLET VALVE (53786) 84622		EA		1	*	2	2	3		C2	26
00097 0		5310-720-8531	NUT, PLAIN, HEXAGON: DISCHARGE VALVE BODY MTG, 5/8-11 THD SIZE		EA		8						C2
00098 0	4730-082-1181	NUT, PLAIN, HEXAGON: FLAP VALVE, 3/8-16 THD SIZE		EA		4						C2	5
00099 0		5305-011-4725	PLUG, PIPE: DISCHARGE VALVE BODY, 3/8-18 THD SIZE		EA		1						C2
00100 0	5307-364-0373	SCREW, MACHINE FLAP VALVE MTG, 3/8-16 THDO SIZE, 1 1/4 IN. LG		EA		2						C2	14
00101 X20		5310-011-5776	STUD, PLAIN: DISCHARGE VALVE BODY MTG, 5/8-11 THD SIZES 2 1/4 IN. LG		EA		8						C2
00102 P 0	4320-724-1359	VALVE ASSEMBLY, INLET (53786) B62284		EA		1							
00103 X20		5310-011-5776	FLAP: INLET VALVE (53786) 62281		EA		1	*	*	*	2		C2
00104 0	5310-720-8531	KEEPER, FLAP VALVE (53786) 61985		EA		1						C2	24
00105 0		5305-011-4407	NUT, PLAIN, HEXAGON: FLAP DOOR MTG, BRASS, 3/8-16 THO SIZE		EA		2						C2
00106 0	5305-011-4720	SCREW, MACHINE: FLAP DOOR, KEEPER, 5/16-18 THD SIZE, 3/4 IN. LG		EA		2						C2	23
00107		5305-011-4720	SCREW, MACHINE: FLAP DOOR MTG, 3/8-16 THO SIZE, 3/4 IN. LG		EA		2						C2

C-13

(1) SMR CODE	(2) FEDERAL STOCK NUMBER	(3) DESCRIPTION REFERENCE NUMBER & MFR CODE USABLE ON CODE		(4) UNIT OF ISSUE	(5) QTY INC IN UNIT	(6) QTY INC IN UNIT	(7) 15-DAY ORGANIZATIONAL MAINTENANCE ALW				(8) ILLUS- TRATION	
							(a) 1-5	(b) 6-20	(c) 21-50	(d) 51-100	(a) FIGURE NO.	(b) ITEM NO.
P 0	4320-725-1803	VALVE, INLET (53786) 265244A		EA		1	*	*	*	2	C2	28
00108 0	5310-033-3957	WASHER, FLAT: FLAP DOOR MTG, BRASS, 3/8 IN. SCREW SIZE		EA		2					C2	4
00109- X20		WASHER FLAT: VALVE (53786) 61987		EA		1					C2	25
00110 X20		WEIGHT, FLAP VALVE (53786) 61958A		EA		1					C2	21
00111 X20		WASHER, FLAP VALVE (53786) 61897		EA		1					C2	13
00112 0	5310-033-3957	WASHER, FLAT: FLAP VALVE MTG, BRASS, 3/8 IN. SCREW SIZE		EA		2					C2	4
00113 0	5310-013-1140	WASHER, LOCK: DISCHARGE VALVE BODY MTG, 5/8 IN. SCREW SIZE		EA		8					C2	9
00114 X20		WEIGHT, FLAP VALVE (53786) 61899A		EA		1					C2	11
00115 00116 X20		5507 - PUMP DRIVE, REDUCTION GEARCASE AIR VENT (80749) 7600		EA		1					C3	10
00118 0	4730-278-3191	BUSHING, PIPE: AIR VENT, 3/4 IN. MALE, 1/8 IN. FEMALE		EA		1					C3	11
00125 0	4730-228-1617	CAP, PIPE: OIL FILL, 1/4-18 THO SIZE		EA		1					C3	17
00126 0	4730-555-782	ELBOW, PIPE: OIL FILL, 1/4 MALE ONE END, 1/4 FEMALE OTHER END		EA		1					C3	19
00129 0	4730-012-2727	NIPPLE, PIPE: OIL FILL, 1/4-18 THND SIZE, 7/8 IN. LG		EA		1					C3	18
00137 0 00139	4730-288-8572	PLUG, PIPE: OIL DRAIN, 1/4-18 THD SIZE		EA		2					C3	7

(1) SMR CODE	(2) FEDERAL STOCK NUMBER	(3) DESCRIPTION REFERENCE NUMBER & MFR CODE USABLE ON CODE		(4) UNIT OF ISSUE	(5) QTY INC IN UNIT	(6) QTY INC IN UNIT	(7) 15-DAY ORGANIZATIONAL MAINTENANCE ALW				(8) ILLUS- TRATION	
							(a) 1-5	(b) 6-20	(c) 21-50	(d) 51-100	(a) FIGURE NO.	(b) ITEM NO.
00175 P O 00176	4730-194-3776	5508 - LUBRICATORS CUP, GREASE: 1/8 THD SIZE (54275) 00-1-81NCH		EA		1	*	*	*	*	C1	9

(1) SMR CODE	(2) FEDERAL STOCK NUMBER	(3) DESCRIPTION REFERENCE NUMBER & MFR CODE USABLE ON CODE		(4) UNIT OF ISSUE	(5) QTY INC IN UNIT	(6) QTY INC IN UNIT	(7) 15-DAY ORGANIZATIONAL MAINTENANCE ALW				(8) ILLUS- TRATION	
							(a) 1-5	(b) 6-20	(c) 21-50	(d) 51-100	(a) FIGURE NO.	(b) ITEM NO.
00002		SECTION IV- REPAIR PARTS FOR DS AND GS MAINTENANCE										
00003		GROUP 01 - ENGINE										
00004		0100 - ENGINE ASSEMBLY										
X2F		BRACKET, ENGINE MOUNTING: CARBURETOR SIDE		EA	1	C4	4					
00005		(53786) 102-3582-1										
X2F		BRACKET, ENGINE MOUNTING:FUEL TANK SIDOE		EA	1	C4	15					
00006		(53786) 502-4309-80										
P F R	2805-072-4871	ENGINE ASSEMBLY, MILITARY STANDARD MODEL 2A016-111 C3 36		EA	1	*	2	2	*	2	2	20
0007		NUT, PLAIN, HEXAGON: ENGINE MTG BRACKET,		EA	2	C4	1					
F-	5310-042-7018	1/2-13 TND SIZE										
00008		SCREW, CAP, HEXAGON HEAD: ENGINE MTG, 1/4-20		EA	12	C4	5					
F	5505-017-9795	THD SIZE, 3/4 IN. LG										
00009		SCREW, CAP, HEXAGON HEAD: ENGINE MTG BRACKET,		EA	2	C4	8					
F	5305-206-0012	1/2-13 THO SIZE, 1 1/4 IN. LG										
00010		SHIM, ENGINE MOUNTING (As REQUIRED)		EA	C4	3						
X2F		(53786) 102-7711-2										
00011		SHIM, ENGINE MOUNTING (As REQUIRED)		EA	C4	3						
X2F		(53786) 102-7711-1										
00012		WASHER, FLAT: ENGINE MTG BRACKET, 1/2 IN. SCREW SIZE		EA	2	C4	7					
F	5310-720-6130											
00013		WASHER, LOCK: ENGINE MTG, 1/4 IN. SCREW SIZE		EA	12	C4	6					
F	5310-812-4403											
00014		WASHER, LOCK: ENGINE NTG BRACKET, 1/2 IN. SCREW SIZE		EA	2	C4	2					
F	5310-012-0239											
00015		0107 - ENGINE STARTING SYSTEMS										
000150		ROPE, STARTING: ENGINE		EA	11	1	2	2	3	2	2	3
P 0	2990-972-7950											
30		(97403) 9786E121										
00016												

(1) SMR CODE	(2) FEDERAL STOCK NUMBER	(3) DESCRIPTION REFERENCE NUMBER & MFR CODE USABLE ON CODE		(4) UNIT OF ISSUE	(5) QTY INC IN UNIT	(6) QTY INC IN UNIT	(7) 15-DAY ORGANIZATIONAL MAINTENANCE ALW				(8) ILLUS- TRATION		
							(a) 1-5	(b) 6-20	(c) 21-50	(d) 51-100	(a) FIGURE NO.	(b) ITEM NO.	
0016A 00017 X20 00018 P 0	2910-717-3790	GROUP 03 - FUEL SYSTEM 0306- TANKS, LINE, FITTINGS FELT FUEL TANK (54275) 1-8X1X221-2LG		EA		2					C4	22	
		FUEL TANK		EA		1	*	*	2	*	2	6	
00019 P 0	2910-717-3792	(54275) 102-3583-1 CAP: FUEL TANK, WITH GASKET		EA		1	*	*	2	*	2	6	
00020 P 0	4320-111-5163	(78252) 2302J012 STRAINER: FUEL TANK		EA		1	*	*	2	*	2	6	
00021 P 0	2910-724-1423	(78252) 2343Bo51 LINE ASSEMBLY, FUEL		EA		1	*	*	2	*	2	10	
00022 P 0	4730-349-4276	(53786) 502-2674-80 NIPPLE, SPECIAL: 1/8 IN.		EA		2	*	*	2	*	2	6	
00023 0	5310-050-6652	(53786) 298-12011-86 NUT, PLAIN, HEXAGON: TANK MTG, 3/8-16 THD SIZE		EA		4					C4	16	
00024 X20	5310-534-3703	STRAP, FUEL TANK MOUNTING		EA		2					C4	21	
00025 0		(53786) 502-2673-80 WASHER, LOCK: TANK MTG, 3/8 IN. SCREW SIZE		EA		4						C4	17
00026 00027 00028 X2F		GROUP 11 - REAR AXLE 1100 - REAR AXLE ASSEMBLY AXLE, REAR		EA		1						C4	34
00029 F 00030	5310-050-6652	(53786) 502-43083-8 NUT, PLAIN, HEXAGON: AXLE MTG, 3/8-16 THO SIZE		EA		6					C4	16	

(1) SMR CODE	(2) FEDERAL STOCK NUMBER	(3) DESCRIPTION REFERENCE NUMBER & MFR CODE USABLE ON CODE		(4) UNIT OF ISSUE	(5) QTY INC IN UNIT	(6) QTY INC IN UNIT	(7) 15-DAY ORGANIZATIONAL MAINTENANCE ALW				(8) ILLUS- TRATION	
							(a) 1-5	(b) 6-20	(c) 21-50	(d) 51-100	(a) FIGURE NO.	(b) ITEM NO.
F	5305-862-6901	SCREW, CAP, HEXAGON HEAD: AXLE me, 3/8-16 TND SIZE, 00031 1 IN. LG		EA		6					C4	29
F	530-5261-1879	SCREW, CAP, HEXAGON HEAD: AXLE MTG, 3/816 TND SIZE, 3 IN. LO		EA		2					C4	33
00032 F	5310-122-5606	WASHER, FLAT: AXLE MTG, 3/8 IN. SCREW SIZE		EA		6					C4	28
00033 F	5310-534-3703	WASHER, LOCK: AXLE HTG, 3/8 IN. SCREW SIZE		EA		6					C4	17
0003 00035 00036 X20		GROUP 13 - WHEELS 1311 - WHEEL ASSEMBLY CAP, HUB (53786) 61844A				2					C4	38
00037 0	5310-543-5626	NUT, PLAIN, HEXAGON: HUB CAP MTG, 1/4-20 THD SIZE		EA		2					C4	25
00038 0	5305-616-6370	SCREW, CAP, HEXAGON HEAD: HU8 CAP MTG, 1/1020 THD SIZE, 1 3/4 IN. LG				2					C4	37
00039 x20		WASHER, AXLE (53786) 61860		EA		4					C4	35
00040 0	5310-812-4403	WASHER, LOCK: Hue CAP me, 1/4 IN. SCREW SIZE		EA		2					C4	26
0001 X20		WHEEL, SEMIPNEUMATIC TIRE (53786) 298-5 75-7		EA		2					C4	36
000402 00043 0001 X2F		GROUP 15 - FRAME 1501 - FR ASSE BLY CHAIN: PUMP DRIVE No. 1 TWIST LINK, 10 LINKS :A (53786) 398-99003-75		EA		1					C4	32
00015												

C-18

(1) SMR CODE	(2) FEDERAL STOCK NUMBER	(3) DESCRIPTION REFERENCE NUMBER & MFR CODE USABLE ON CODE		(4) UNIT OF ISSUE	(5) QTY INC IN UNIT	(6) QTY INC IN UNIT	(7) 15-DAY ORGANIZATIONAL MAINTENANCE ALW				(8) ILLUS- TRATION	
							(a) 1-5	(b) 6-20	(c) 21-50	(d) 51-100	(a) FIGURE NO.	(b) ITEM NO.
X2F 00046		FRAME, PUMP MOUNTING (53786) 502-5920-80		EA		1					C4	14
F 00047	5310-543-5626	NUT,PLAIN,HEXAGON: PUMP FRAME, ¼-20 THD SIZE		EA		4					C4	25
F 00048	5310-637-3675	NUT,PLAIN, HEXAGON:PUMP MTG, ¾-4-10 THD SIZE		EA		4					C1	16
F 00049	5305-017-9795	SCREW,CAP,HEXAGON HEAD: PUMP FRAME, ¼-20 THD SIZE, ¾ IN. LG		EA		2					C4	5
F 00050	5305-207-8253	SCREW,CAP,HEXAGON HEAD: PUMP FRAME, ¼-20 THD SIZE, 1 IN. LG		EA		2					C4	31
F 00051	5305-022-1135	SCREW,CAP,HEXAGON HEAD:PUMP MTG, ¾-10 THD SIZE, 2 ¾ IN. LG		EA		4					C1	13
F 00052	5310-205-8643	WASHER, FLAT:PUMP FRAME, ¼ IN. SCREW SIZE		EA		4					C4	30
F 00053	5310-721-3682	WASHER,FLAT:PIUMP MTG, ¾ IN. SCREW SIZE		EA		4					C1	14
F 00054	5310-812-4403	WASHER,LOCK:PUMP FRAME, ¼ IN. SCREW SIZE		EA		4					C4	26
F 00055	5310-595-7204	WASHER,LOCK: PUMP MTG. ¾ IN. SCREW SIZE		EA		4					C1	15
00056		1503 - TOWING ATTACHMENTS										
X20 00057		BAIL,TOWING (53786) 266029		EA		1					C4	27
0 00058	5310-050-6652	NUT,PLAIN,HEXSAGON:BAIL MTH, 3/8-16 THD SIZE		EA		2					C4	16
0 00059	5305-862-6901	SCREW,CAP,HEXAGON HEAD:BAIL MTG, 3/8-16 THD SIZE, 1 IN. LG		EA		2					C4	29
0 00060	5310-534-3703	WASHER, FLAT:BAIL MTG, 3/8 IN SCREW SIZE		EA		2					C4	17

(1) SMR CODE	(2) FEDERAL STOCK NUMBER	(3) DESCRIPTION REFERENCE NUMBER & MFR CODE USABLE ON CODE		(4) UNIT OF ISSUE	(5) QTY INC IN UNIT	(6) QTY INC IN UNIT	(7) 15-DAY ORGANIZATIONAL MAINTENANCE ALW				(8) ILLUS- TRATION	
							(a) 1-5	(b) 6-20	(c) 21-50	(d) 51-100	(a) FIGURE NO.	(b) ITEM NO.
0 00061	5310-122-5606	WASHER, LOCK: BAIL MTG, 3/8 IN. SCREW SIZE		EA		2	C4	28				
00062		GROUP 22 - ACCESSORY ITEMS										
00063		2202 - HOSES										
P 0	4720-202-8653	HOSE, WATER: SUCTION		EA		4	4	*	2	*	*	2
6		(81349) ZZH561 TYPE									C2	2
00064		NIPPLE, PIPE: INLET VALVE TO HOSE, 4 IN. DIA		EA		2					C2	1
0	4730-256-7130	6 IN. LO										
00065		2210 - DATA PLATES										
00066	5310-167-1364	NUT, PLAIN, HEXAGON: PLATE MTG, No. 6 SCREEN SIZE		EA		8					C4	13
0		PLATE, IDENTIFICATION: U.S. DEPARTMENT OF THE ARMY		EA		1					C4	11
00067		(53786) 102-7701-1										
X20		PLATE, IDENTIFICATION: TRANSPORTATION DATA		EA		1					C4	10
00068		(53786) 102-7700-1										
00069	5305-010-0945	SCREW, NACHINE: PLATE MTG, No. 6-32 THO I"ZE,		EA		8					C4	9
0		3/8 IN. LG										
00070	5310-514-6612	WASHER, LOCK: PLATE MTG) No. 6 SCREW SIZE		EA		8					C4	12
0		GROUP 55 - PUMPS										
00071		5500 - PUMPS ASSEMBLY										
00072		BODY, PUMP		EA		1					C2	20
00073		(53786) 502-5916-80										
X2F	4320-725-1805	CAP, LIFT, PRIME PLUG		EA		1	*	*	*	*	*	*
00074											C2	3
P 0												
00075		(53786) 58669A										

(1) SMR CODE	(2) FEDERAL STOCK NUMBER	(3) DESCRIPTION REFERENCE NUMBER & MFR CODE USABLE ON CODE		(4) UNIT OF ISSUE	(5) QTY INC IN UNIT	(6) QTY INC IN UNIT	(7) 15-DAY ORGANIZATIONAL MAINTENANCE ALW				(8) ILLUS- TRATION	
							(a) 1-5	(b) 6-20	(c) 21-50	(d) 51-100	(a) FIGURE NO.	(b) ITEM NO.
X20 00076 P 0	4320-724-1360	DOOR, CLEANOUT (53786) 102-3570		EA		1					C2	17
		GASKET, DOOR CLEANOUT		EA		1	2	3	5	2	3	5
00077 0	5310-720-8393	(53786) 84624 NUT, PLAIN, WING: CLEANOUT DOOR, 1/2-13 THD SIZE		EA		4			60	C2	19	
00078 0	4730-278-3363	PLUG, PIPE: CLEANOUT COVER, 1-11 1/2 THD SIZE		EA		1						C2 18
00079 0	5307-261-0354	STUD, PLAIN: CLEANOUT COVER MTG, 1/2-13 THD SIZE, 1 3/4 IN. LG		EA		4				C2	16	
00080 00081 P 0	3110-112-6026	5502 - RODS, BEARINGS, DIAPHRAGM BEARING, NEEDLE: PUMP SHAFT		EA		1	*	2	2	*	2	2
		(60399) BR2020 DIAPHRAGM ASSEMBLY, RUBBER		EA		1				15	C1	7
00082 X20 00083 P 0	4320-730-5905	(53786) 883210 DIAPHRAGM, RUBBER		EA		1	2	2	4	2	4	
	(53786) x5062 FLANGE, DIAPHRAGM		EA		1	*	*	2	*	*	2	
00084 P 0	4320-725-1784							6		C1	4	
00085 0	5310-011-5776	(53786) 60208A NUT, PLAIN, HEXAGON: DIAPHRAGM MTG, BRASS, 5/8-11 THD SIZE		EA		2				C1	2	
00086 X20		ROD, CONNECTING		EA		1					C1	6
00087 0	5307-261-0381	(53786) A79520 STUD, PLAIN: DIAPHRAGM MTG, 5/8-11 THD SIZE, 3 1/4 IN. LG		EA		2				C1	3	
00088 P 0	5315-985-4432	PIN, DOWEL: ROD MTG		EA		1	*	2	2	*	2	2
									15		C1	8
00089												

(1) SMR CODE	(2) FEDERAL STOCK NUMBER	(3) DESCRIPTION		(4) UNIT OF ISSUE	(5) QTY INC IN UNIT	(6) QTY INC IN UNIT	(7) 15-DAY ORGANIZATIONAL MAINTENANCE ALW				(8) ILLUS- TRATION	
							(a) 1-5	(b) 6-20	(c) 21-50	(d) 51-100	(a) FIGURE NO.	(b) ITEM NO.
INDEX NO.	REFERENCE NUMBER & MFR CODE	USABLE ON CODE										
0 00090 P 0	5305-558-3692	SCREW, CAP, HEXAGON HEAD: ROD MTG, 1/2-13 THD SIZE, 1 IN. LG	EA		1	C1	10					
	4320-728-7394	WASHER, BEARING, RETAINER	EA		1	*	*	2 6	*	*	2 12	
00091 0	5310-010-6500	(53786) 61893 WASHER, LOCK: ROD NTG, 1/2 IN. SCREW SIZE	EA		1					C1	11	
00092 00093 X20		5505 - SUCTION AND DISCHARGE ASSEMBLY BODY, DISCHARGE VALVE	EA		1					C2	6	
00094 P 0	4320-724-1361	(53786) 290542A FLAP: DISCHARGE VALVE	EA		1	*	2	2 12	*	2 C2	2 12	
00095 P 0	4320-728-7395	(53786) 101-3581-1 GASKET, INLET VALVE	EA		1	2	3	5 60	2	3 C2	5 26	
00096 0	5310-011-5776	(53786) 84622 NUT, PLAIN, HEXAGON: DISCHARGE VALVE BODY MTG, 5/8-11 THD SIZE	EA		8					C2	7	
00097 0	5310-720-8531	NUT, PLAIN, HEXAGON: FLAP VALVE, 3/8-16 THD SIZE	EA		4					C2	5	
00098 0	4730082-1181	PLUG, PIPE: DISCHARGE VALVE BODY, 3/8-18CTHD SIZE	EA		1					C2	10	
00099 0	5305-011-4725	SCREW, MACHINE: FLAP VALVE NTG, 3/8-16 THD SIZE, 1 1/4 IN. LG	EA		2					C2	11	
00100 0	5307-364-0373	STUD, PLAIN: DISCHARGE VALVE BODY MTG, 5/8-11 THD SIZE, 2 1/4 IN. LG	EA		8					C2	8	
00101 X20		VALVE ASSEMBLY, INLET	EA		1							
00102 P 0	4320-724-1359	(53786) B62284 FLAP: INLET VALVE	EA		1	*	2	2 12	*	2 C2	2 22	
00103 X20 00104	(53786) 61985	(53786) 62281 KEEPER, FLAP VALVE	EA		1					C2	24	

(1) SMR CODE	(2) FEDERAL STOCK NUMBER	(3) DESCRIPTION REFERENCE NUMBER & MFR CODE USABLE ON CODE		(4) UNIT OF ISSUE	(5) QTY INC IN UNIT	(6) QTY INC IN UNIT	(7) 15-DAY ORGANIZATIONAL MAINTENANCE ALW				(8) ILLUS- TRATION	
							(a) 1-5	(b) 6-20	(c) 21-50	(d) 51-100	(a) FIGURE NO.	(b) ITEM NO.
0 00105	5310-720-8531	NUT, PLAIN, HEXAGON: FLAP DOOR MTG, BRASS, 3/8-16 THD SIZE		EA	2					C2	5	
0 00106	5305-011-4407	SCREW, MACHINE: FLAP DOOR, KEEPER, 5/16-18 THD SIZE, 3/4 IN. LG		EA	2					C2	23	
0 00107	5305-011-4720	SCREW, MACHINE: FLAP DOOR MTG, 3/8-16 THD SIZE, 3/4 IN. LG		EA	2					C2	27	
P 0	4320-725-1803	VALVE, INLET		EA	1	*	2	2	*	2 C2	2 28	
00108 0	5310-033-3957	(5386) 265244A WASHER, FLAT: FLAP DOOR MTG, BRASS, 3/8 IN. SCREW SIZE		EA	2					C2	4	
X20 00109		WASHER, FLAT: VALVE (53786) 61987		EA	1					C2	25	
X20 00110		WEIGHT, FLAP VALVE (53786) 61958A		EA		1				C2	21	
X20 00111		WASHER, FLAP VALVE (53786) 61897		EA	1					C2	13	
0 00112	5310-033-3957	WASHER, FLAT: FLAP VALVE MTG, BRASS, 3/8 IN. SCREW SIZE		EA	2					C2	4	
0 00113	5310-013-1140	WASHER, LOCK: DISCHARGE VALVE BODY MTG, 5/8 IN. SCREW SIZE		EA	8					C2	9	
X20 00114		WEIGHT, FLAP VALVE (53786) 61899A		EA		1				C2	11	
P F 00115	4320-717-1382	5507 - PUMP DRIVE, REDUCTION GEARCASE GEARCASE ASSEMBLY, FINAL REDUCTION		EA	1	*	**	*	*	*	5	
X20 00116		(53786) C13304 AIR VENT		EA			1			C3	10	
P F 00117	3110-156-3576	(80749) 7600 BEARING, BALL: CRANKSHAFT		EA	1	*	*	2	*	* C3	2 4	
00118 00119		(21335) 207KLL							6			

(1) SMR CODE	(2) FEDERAL STOCK NUMBER	(3) DESCRIPTION REFERENCE NUMBER & MFR CODE USABLE ON CODE		(4) UNIT OF ISSUE	(5) QTY INC IN UNIT	(6) QTY INC IN UNIT	(7) 15-DAY ORGANIZATIONAL MAINTENANCE ALW				(8) ILLUS- TRATION	
							(a) 1-5	(b) 6-20	(c) 21-50	(d) 51-100	(a) FIGURE NO.	(b) ITEM NO.
P F	3110-155-6679	BEARING, BALL: CRANKSHAFT		EA		1	*	*	2	*	*	2
00120 P F	3110-155-6401	(21335) 207W BEARING, BALL: GEARSHAFT		EA		1	*2	*	*	2	6	C3 23
00121 P F	3110-155-6661	(21335) 205w BEARING, BALL: GEARSHAFT		EA		1	*	*	2	*	*	2
6 00122 F	5306-543-4405	C3 26 (21335) 206W BOLT, MACHINE: COVER TO GEARCASE, 5/16-18		EA		6					C3	8
00123 F	5306-298-2653	THD SIZE, 1 IN. LG BOLT, MACHINE: GEARCASE TO COVER, 5/16-18		EA		6					C3	54
00124 0	4730-278-3191	TND SIZE, 3/4 IN. LG BUSHING, PIPE: AIR VENT, 3/4 IN. MALE, 1/8		EA		1					C3	11
00125 0	4730-228-1617	IN. FEMALE CAP, PIPE: OIL FILL, 1/4-18 THDO SIZE		EA		1					C3	17
00126 X2F		CASE, GEAR, ENGINE SIDE		EA		1					C3	55
00127 X2F		(53786) 402-2601-1 CASE, GEAR. PUM,P SIDE		EA		1					C3	12
00128 0	4730-555-0782	(53786) 3942A ELBOW, PIPE: OIL FILL, 1/4 MALE ONE EN, 1/4		EA		1					C3	19
00129 P F	4320-728-7393	FEMALE OTNER END GASKET: GEARCASE		EA		1	2	3	5	2 60	3 C3	5 56
00130 P F	4320-725-1388	(53786) 62175 GEAR, HELICAL: CRANKSHAFT DRIVE		EA		1	*	*	*	*	*	5 22
00131 P F	4320-724-1357	(53786) 84361A GEAR, SPUR: SPEED REDUCING		EA		1	*	*	*	*	*	* 35
00132 P F	4320-725-1383	JACK SHAFT AND PINION		EA		1	*	*	*	*	*	* 24
00133 F 00134	5315-732-0577	(53786) 62176 KEY, MACHINE: DRIVE GEAR, 5/16 IN. SQ, 1 1/4 IN. LG		EA		1	C3	3				

(1) SMR CODE	(2) FEDERAL STOCK NUMBER	(3) DESCRIPTION REFERENCE NUMBER & MFR CODE USABLE ON CODE		(4) UNIT OF ISSUE	(5) QTY INC IN UNIT	(6) QTY INC IN UNIT	(7) 15-DAY ORGANIZATIONAL MAINTENANCE ALW				(8) ILLUS- TRATION		
							(a) 1-5	(b) 6-20	(c) 21-50	(d) 51-100	(a) FIGURE NO.	(b) ITEM NO.	
F 00135	5315-197_1804	KEY, MACHINE: SPUR GEAR, 1/4 IN. SQ, 1 3/16 IN. LO		EA		1					C3	25	
P F 00136	3110-185-6463	LOCKNUT: OUTPUT SHAFT (60399) N065		EA		1	*	*		*	C3	25	
0 00137	4730-012-2727	NIPPLE, PIPE: OIL FILL, 1/4-18 THO SIZE, 7/8 IN. LG		EA		1					C3	28	
P F C3 00138	4320-724-1358	PIN, CRANK: OUTPUT SHAT 2 (53786) 502-4079-80		EA		1	*	*	*	*	*	C3	18
0 00139	4730-288-8572	PLUG, PIPE: OIL DRAIN, 1/4-18 THO SIZE		EA		2					C3	7	
P F 00140	4320-725-1781	RETAINER BEARING (53786) 61896		EA		1	*	*	*	*	&		
X2F 00141		RING, RETAINING: CRANKSHAFT (81910) X7233		EA							C3	20	
X2F 00142		RING, RETAINING: SPUR GEAR (53786) X722-9		EA							C3	34	
F 00143	5305-983-5344	SCREW, CAP, SOCKET HEAD: BEARING RETAINER NTG, 5/16-18 TND SIZE, 1/2 IN. LG		EA		3					C3	32	
F 001144	5305-423_7247	SCREW, MACHINE: LOCK PLATE MTG, 1/4-20C THD SIZE, 1/2 IN. LG		EA		2					C3	15	
F 0015	-5305-022-2404	SETSCREW, SOCKET HEAD: BEARING LOCK, 1/4-20 THD SIZE, 5/16 IN. LG		EA		1					C3	15	
X2F 00146		SLINGER, OIL (53786) A2020149		EA								30	
P F 00147	5340-702-8999	SPACER, BEARING (53786) 61900		EA		1	2	2	6		C3	16	
P F 00148	5340-707-7768	SPACER: OUTPUT SHAFT (53786) 102_6794-1											
X2F 00149-		TRAP, OIL (53786) 61891-2											

(1) SMR CODE	(2) FEDERAL STOCK NUMBER	(3) DESCRIPTION REFERENCE NUMBER & MFR CODE USABLE ON CODE		(4) UNIT OF ISSUE	(5) QTY INC IN UNIT	(6) QTY INC IN UNIT	(7) 15-DAY ORGANIZATIONAL MAINTENANCE ALW				(a) FIGURE NO.	(b) ITEM NO.
							(a) 1-5	(b) 6-20				
X2F 00150 F	5310-51-6610	W ASHER, KEY: SHAFT LOCKNUT (60399) W06		EA-		1					C3	27
00151- F		WASER, LOCK: BEARING RETAINER, 5/16 IN. SCREW SIZE INTERNAL TEETH		EA		3						C3
00152 F	5310-261-739	WASHER, LOCK: GEAR COVER, 5/16 IN. SCREW SIZE		EA		12					C3	9
00153 X2F	5310-812-03	WASHER, LOCK: LOCK PLATE Ts 1/4 IN. SCREW SIZE		EA		2					C3	14
0015 P F	3110-554-5403	GESE ASSE4BLY, INTERMEDIATE REDUCTION (53786) 70-951-1		EA		1					C3	
		BEARING BALL: GEARSHAFT		EA		1	*	2	*	*	2	6
00155 P F	3110-554-3197	(21335) 298.2602									C3	49
		BEARING, BALL: GEARSNAFT		EA		1	*	*	2	*	*	2
00156 2F	BOLT, T7	(213351) 2982612									C3	51
00157		MACHINE, SELF5-LOCKING: HOUSING MTG, 5/16-2 SIZE, IN. LO		EA		1						C3
P F	1320-172-1356	(5275) 1 832D.. 12										
		GASKET: GEARCASE		EA		2	2	3	5	2	3	5
00158 P F	5330-689-7310	(537) 102-3579-1									C3	52
		GASKET: INTERNEDIATE GEARCASE		EA		1	*	2	2	*	2	2
00159 X20 F	5315 060-4138	(53786) 102-102-1									C3	37
00161 F		GEARCASE, ENGINE SIDE		EA		1						C3
00162	5310-616-1291	KEY,WOODFRUFF:GEARSHAFT, No. 61, 3/16 IN. v, 5,8 IN. LO		EA		1					C3	45
		NUT, PLAIN, HEXAGON: GEARCASE ADJUSTING, 3/8-16 THD SIZE		EA		2					C3	40
P F	4320O-721351	(54275) 3-8x16										
		PINION ENGINE SHAFT		EA		1	*	*	2	*	*	2
001063 P F	3110-022-8408	(53786) 103580-1									C3	46
		8 RETAINER, BEARING		EA	1	*	*	2	*	*	2	6
		00164									C3	53

(1) SMR CODE	(2) FEDERAL STOCK NUMBER	(3) DESCRIPTION REFERENCE NUMBER & MFR CODE USABLE ON CODE		(4) UNIT OF ISSUE	(5) QTY INC IN UNIT	(6) QTY INC IN UNIT	(7) 15-DAY ORGANIZATIONAL MAINTENANCE ALW				(8) ILLUS- TRATION	
							(a) 1-5	(b) 6-20	(c) 21-50	(d) 51-100	(a) FIGURE NO.	(b) ITEM NO.
F 00165	530582-6901	SCREW, CAP, HEXAGON HEAD: GEARCASE ADJUSTING, 3/8-16 THD SIZE, 1 IN. LG		EA		2					C3	41
F 00166	5305-17-9845	SCREW, CAP, HEXAGON HEAD GEARCASE TO GEARCASE, 3/8-16 TND SIZE, 1 3/4 IN. LG		EA		5					C3	38
X2F 00167		SCREW, CAP, SELF-LOCKING: GEARCASE TO ENGINE, 5/16-21 THO SIZE, 7/8 IN. LG (54275) M38D52-14C		EA		3					C3	44
X2F 00168		SCREW, CAP, SELF-LOCKING: PINION MTG (54275) Ms32DS524-12C		EA		1					C3	47
P F	4320-24-1355	SHAFT, GEAR AND PINION		EA		1	*	*	2	*	*	2
00169		(53786) 102-4481-1								6	C3	50
P F 6	5310-701-8280	WASHER, FLAT: PINION MTG C3 48		EA		1	*	*	2	*	*	2
00170		(53786) 102-7703-1										
F 00171	5310-5311-3703	WASHER, LOCK: GEARCASE, 3/8 IN. SCREW SIZE		EA		5					C3	39
F 00172	5305-212-6172	SCREW, CAP, HEXAGON HEAD: GEARCASE 14TG, 1/2-13 THD SIZE, 2 IN.		EA LG		2					C3	5
X2F 00173		SHIM, REDUCTION GEAR MTG (As REQUIRED) (53786) 61909-2		EA							C3	6
X2F 00175		SHIM, REDUCTION GEAR MTG (As REQUIRED) (53786) 6199-11		EA							C3	6
00175		5508 - LUBRICATORS										
P O 00176	4730-019-3776	CUP, GREASE: 1/8 THD SIZE (54275) 00-1-81NCH		EA	1	*	*	2	*	*	2 C1	6 9

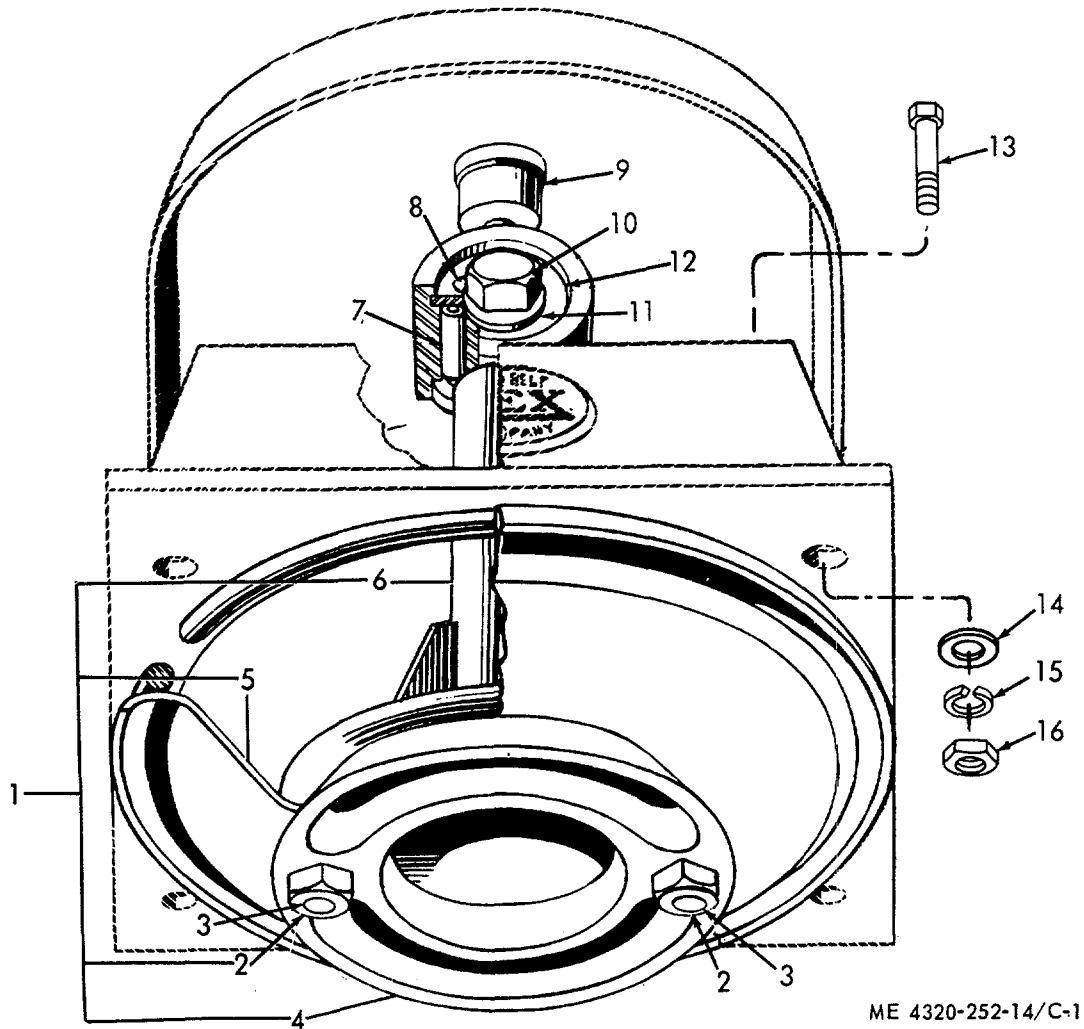
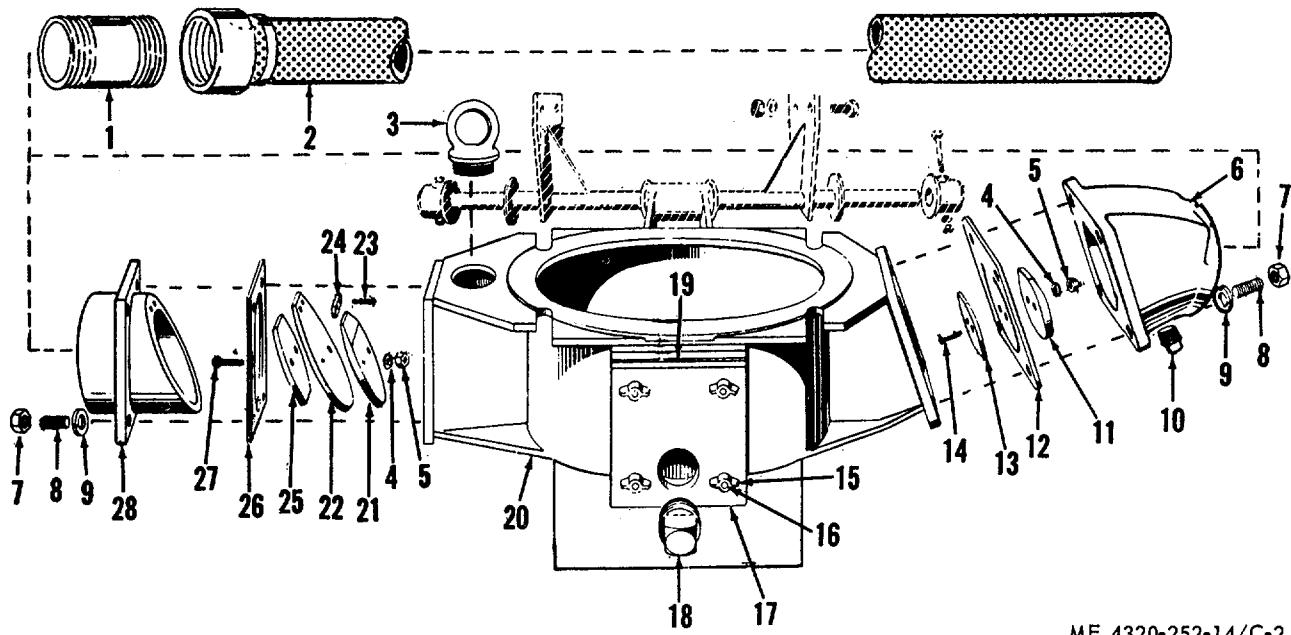

Figure No. C-1. Diaphragm And Connecting Rod

LEGEND TO PARTS, FIGURE C-1

ITEM NO.	FUNCT GROUP	ITEM NAME	ITEM NO.	FUNCT GROUP	ITEM NAME
1	5502	DIAPHRAGM AY	9	5508	CUP
2	5502	NUT	10	5502	SCREW
3	5502	STUD	11	5502	WASHER
4	5502	FLANGE	12	5502	WASHER
5	5502	DIAPHRAGM	13	1501	SCREW
6	5502	ROD	14	1501	WASHER
7	5502	BEARING	15	1501	WASHER
8	5502	PIN	16	1501	NUT



ME 4320-252-14/C-2

Figure No. C-2 Pump Body And Valves

LEGEND TO PARTS, FIGURE C-2

ITEM NO.	FUNCT GROUP	ITEM NAME	ITEM NO.	FUNCT GROUP	ITEM NAME	ITEM NO.	FUNCT GROUP	ITEM NAME
1	2202	NIPPLE	11	5506	WEIGHT	20	5500	BODY
2	2202	HOSE	12	5506	FLAP	21	5506	WEIGHT
3	5500	CAP	13	5506	WASHER	22	5506	FLAP
4	5506	WASHER	14	5506	SCREW	23	5506	SCREW
5	5506	NUT	15	5500	NUT	24	5506	KEEPER
6	5506	BODY	16	5500	STUD	25	5506	WASHER
7	5506	NUT	17	5500	DCOR.	26	5506	GASKET
8	5506	STUD	18	5500	PLUG	27	5506	SCREW
9	5506	WASHER	19	5500	GASKET	28	5506	VALVE
10	5506	PLUG						

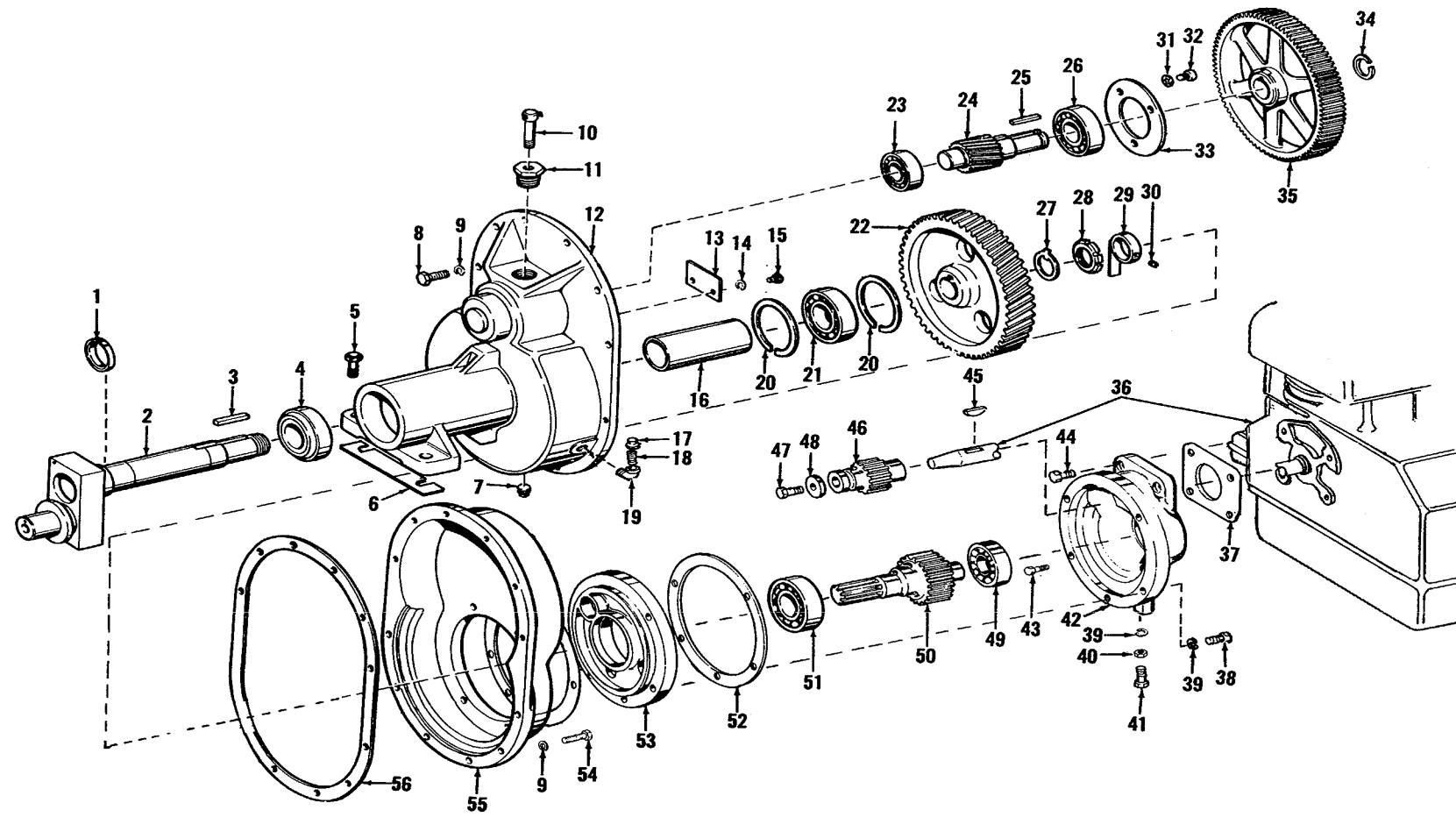
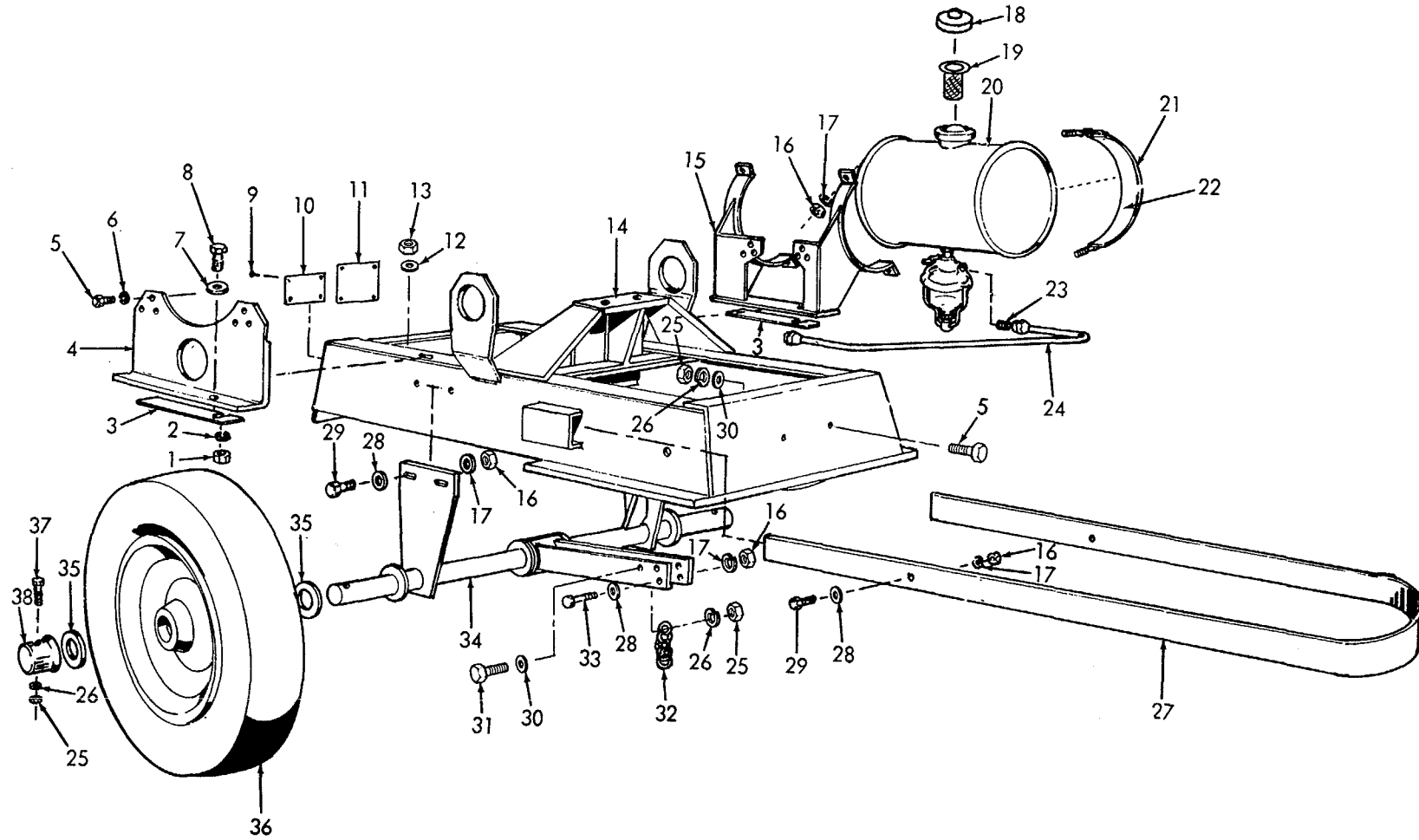

Figure No. C-3. Reduction Gearcase

C-30

LEGEND TO PARTS, FIGURE C-3

ITEM NO.	ITEM GROUP	ITEM NAME	ITEM NO.	FUNCT GROUP	ITEM NAME
1	5507	SPACER	29	5507	SLINGER
2	5507	PIN	30	5507	SETSCREW
3	5507	KEY	31	5507	WASHER
4	5507	BEARING	32	5507	SCREW
5	5507	SCREW	33	5507	RETAINER
6	5507	SHIM	34	5507	RING
7	5507	PLUG	35	5507	GEAR
8	5507	BOLT	36	0100	ENGINE AY
9	5507	WASHER	37	5507	GASKET
10	5507	AIR VENT	38	5507	SCREW
11	5507	BUSHING	39	5507	WASHER
12	5507	CASE	40	5507	NUT
13	5507	TRAP	41	5507	SCREW
14	5507	WASHER	42	5507	GEARCASE
15	5507	SCREW	43	5507	BOLT
16	5507	SPACER	44	5507	SCREW
17	5507	CAP	45	5507	KEY
18	5507	NIPPLE	46	5507	PINION
19	5507	ELBOW	47	5507	SCREW
20	5507	RING	48	5507	WASHER
21	5507	BEAR ING	49	5507	BEARING
22	5507	GEAR	50	5507	SHAFT
23	5507	BEARING	51	5507	BEARING
24	5507	JACK SHAFT-PIN	52	5507	GASKET
25	5507	KEY	53	5507	RETAINER
26	5507	BEAR ING	54	5507	BOLT
27	5507	WASHER	55	5507	CASE
28	5507	LOCKNUT	56	5507	GASKET



ME 4320-252-14/C-4
Figure No. C-4 Pump Frame

LEGEND TO PARTS, FIGURE C-4

ITEM NO.	FUNCT GROUP	ITEM NAME	ITEM NO.	FUNCT GROUP	ITEM NAME
1	0100	NUT	20	0306	FUEL TANK
2	0100	WASHER	21	0306	STRAP
3	0100	SHIM	22	0306	FELT
4	0100	BRACKET	23	0306	NIPPLE
5	0100	SCREW	24	0306	LINE AY
5	1501	SCREW	25	1311	NUT
6	0100	WASHER	25	1501	NUT
7	0100	WASHER	26	1311	WASHER
8	0100	SCREW	26	1501	WASHER
9	2210	SCREW	27	1503	BAIL
10	2210	PLATE	28	1100	WASH:ER
11	2210	PLATE	29	1100	SCREW
12	2210	WASHER	29	1503	SCREW
13	2210	NUT	30	1501	WASHER
14	1501	FRAME	31	1501	SCREW
15	0100	BRACKET	32	1501	CHAIN
16	0306	NUT	33	1100	SCREW
16	1100	NUT	34	1100	AXLE
16	1503	NUT	35	1311	WASHER
17	0306	WASHER	36	1311	WHEEL
17	1503	WASH ER	37	1311	SCREW
18	0306	CAP	38	1311	CAP
19	0306	STRAINER			

Section V. INDEX-FEDERAL STOCK NUMBER AND REFERENCE NUMBER
CROSS-REFERENCE TO INDEX NUMBER

REFERENCE No.	MFR CODE	INDEX NO.	STOCK NUMBER	INDEX NUMBER	STOCK NUMBER	INDEX NUMBER
A202049	53786	00146	2805-072-4871	00007	5310-261-7395	00152
A79520	53786	00087	2910-717-3790	00019	5310-514-6610	00151
BR2020	60399	00082	2910-717-3792	00020	5310-514-6612	00071
B62284	53786	00102	2910-724-1423	00022	5310-534-3703	00026
B83210	53786	00083	2990-972-7950	00016		00034
C13304	53786	00117	3110-022-8408	00164		00060
MS32DS524-12C	54275	00168	3110-112-6026	00082		00171
M32DS524-12C	54275	00157	3110-155-6401	00121	5310-543-5620	00038
M38DS524-14C	54275	00167	3110-155-6661	00122		00047
N06	60399	00136	3110-155-6679	000120	5310-595-7204	00055
W06	60399	00150	3110-156-3576	00119	5310-616-1291	00162
X5062	53786	00084	3110-185-6463	00136	5310-6373675	00048
X722-9	53786	00142	3110-554-3197	00156	5310-701-8280	00170
X7233	81910	00141	3110-554-5403	00155	5310-720-6130	00013
ZZH561TYPE	81349	00064	4320-717-1382	00117	5310-720-8393	00078
00-1-8INCH	54275	00176	4320-724-1354	00163	5310-720-8531	00098
1-8X1X221-2LG	54275	00018	4320-724-1355	00169		00105
101-3581-1	53786	00095	4320-724-1356	00158	5310-721-3682	00053
102-3570	53786	00076	4320-724-1357	00132	5310-812-44036	00014
102-3879-1	53786	00158	4320-724-1358	000138		00041
102-3580-1	53786	00163	4320-724-1359	00103		00054
102-3582-1	53786	00005	4320-724-1360	00077		00153
102-3583-1	54275	00019	4320-724-1361	00095	5315-060-4138	00161
102-4481-1	53786	00109	4320-725-1383	00133	5315-197-1804	00135
102-6794-1	53786	00148	4320-725-1388	00131	5315-732-0577	00134
102-7700-1	53786	00069	4320-725-1781	00140	5315-985-4432	00089
102-7701-1	53786	00068	4320-725-1784	00085	5330-689-7310	00159
102-7702-1	53786	00159	4320-725-1803	00108	5340-702-8999	00147
102-7703-1	53786	00170	4320-725-1805	00075	5340-707-7768	00148
102-7711-1	53786	00012	4320-728-7393	00130	5505-017-9795	00009
102-7711-2	53786	00011	5320-728-7394	00091		
205W	21335	00121	4320-730-5905	00084		
206W	21335	00122	4720-202-8653	00064		
207KLL	21335	00119	4730-012-2727	00137		
207w	21335	00120	4730-082-1181	00099		
2302J012	78252	00020	4730-194-3776	00176		
2343B051	78252	00021	4730-228-1617	00126		
265244A	53786	00108	4730-256-7130	00065		
266029	53786	00057	4730-278-3191	00125		
290542A	53786	00094	4730-278-3363	00079		
498-12011-86	53786	00023	4730-288-8572	00139		
298-260-2	21335	00155	4730-349-4276	00023		
298-261-2	21335	00156	4730-555-0782	00129		
298-4045-47	53786	00042	5305-010-0945	00070		
3-8X16	54275	00162	5305-011-4407	00106		
398-99003-75	53786	00045	5305-011-4720	00107		
402-1683-2	53786	00160	5305-011-4725	00100		
402-2601-1	53786	00127	5305-017-9795	00049		
402-665-2	53786	00164	5305-017-9845	00166		
502-2673-80	53786	00025	5305-022-1135	00051		
502-2074-80	53786	00022	5305-022-2404	00145		
502-4079-80	53786	00138	5305-206-0012	00010		
502-4308-80	53786	00006	5305-212-6172	00172		
502-4309-80	53786	00006	5305-261-1879	00332		
502-5916-80	53786	00074	5305-261-1879	00032		
502-5920-80	53786	00046	5305-423-7247	00144		
58609A	53786	00075	5305-558-3692	00090		
60208A	53786	00075	5305-616-6370	00039		
01844A	53786	00037	5305-862-6901			
61860	53786	00040		00031		
618911-2	53786	00149		00059		
61893	53786	00091	5305-983-5344	00143		
61896	53786	00140	5306-298-2653	00124		
01897	53786	00112	5306-543-4405	00123		
61899A	53786	00115	5307-261-0354	00080		
61900	53786	00147	5307-261-0381	00088		
61909-1	53786	00174	5307-364-0373	00101		
61909-2	53786	00173	5310-010-6500	00092		
61958A	53786	00111	5310-011-5776	00086		
61985	53786	00104		00097		
61987	53786	00110	5310-012-0239	00015		
62175	53786	00130	5310-0013-1140	00014		
62176	53786	00133	5310-033-3957	00109		
62281	53786	00103		00113		
68942A	53786	00128	5310-042-7018	00008		
702-951-1	53786	00154	5310-050-6652	00024		
7600	80749	00118		00030		
84361A	53786	00131		00058		
84622	53786	00096	5310-122-5606	00033		
84624	53786	00077		00061		
9780E121	97403	00016	5310-167-1364	00052		
			5310-205-8643	00052		

By Order of the Secretary of the Army

Official:

KENNETH G. WICKHAM,
Major General, United States Army,
The Adjutant General.

W.C. WESTMORELAND,
General, United States Army,
Chief of Staff.

Distribution:

To be distributed in accordance with DA Form 12-25, Sea I (qty rqr Block #242) requirements for Organizational maintenance, Pumps, Centrifugal, Fresh Water.

*U.S. GOVERNMENT PRINTING OFFICE : 1995 - 388-421 (00468)

RECOMMENDED CHANGES TO EQUIPMENT TECHNICAL PUBLICATIONS



THEN... JOT DOWN THE DOPE ABOUT IT ON THIS FORM, CAREFULLY TEAR IT OUT, FOLD IT AND DROP IT IN THE MAIL!

SOMETHING WRONG WITH THIS PUBLICATION?

FROM: (PRINT YOUR UNIT'S COMPLETE ADDRESS)

DATE SENT

PUBLICATION NUMBER

PUBLICATION DATE

PUBLICATION TITLE

BE EXACT... PIN-POINT WHERE IT IS

PAGE NO.

PARA-GRAPH

FIGURE NO.

TABLE NO.

IN THIS SPACE TELL WHAT IS WRONG AND WHAT SHOULD BE DONE ABOUT IT:

TEAR ALONG PERFORATED LINE

PRINTED NAME, GRADE OR TITLE, AND TELEPHONE NUMBER

SIGN HERE:

DA FORM 2028-2 JUL 79

PREVIOUS EDITIONS ARE OBSOLETE.

P.S.—IF YOUR OUTFIT WANTS TO KNOW ABOUT YOUR RECOMMENDATION MAKE A CARBON COPY OF THIS AND GIVE IT TO YOUR HEADQUARTERS.

